



# ArcPod 15VW

15x10W VW outdoor IP66 LED  
wash light for exterior installations



---

## USER MANUAL

---

## ***Thank you for choosing PROLIGHTS***

Please note that every PROLIGHTS product has been designed in Italy to meet quality and performance requirements for professionals and designed and manufactured for the use and application as shown in this document.

Any other use, if not expressly indicated, could compromise the good condition/operation of the product and/or be a source of danger.

This product is meant for professional use. Therefore, commercial use of this equipment is subject to the respectively applicable national accident prevention rules and regulations.

Features, specifications and appearance are subject to change without notice. Music & Lights S.r.l. and all affiliated companies disclaim liability for any injury, damage, direct or indirect loss, consequential or economic loss or any other loss occasioned by the use of, inability to use or reliance on the information contained in this document.

Product user manual can be downloaded from the website [www.prolights.it](http://www.prolights.it), or can be inquired to the official PROLIGHTS distributors of your territory ([https://www.prolights.it/sales\\_network.html](https://www.prolights.it/sales_network.html)).

Scanning the below **QR Code**, you will access the download area of the product page, where you can find a broad set of always updated technical documentation: specifications, user manual, technical drawings, photometrics, personalities, fixture firmware updates.



**Visit the download area  
of the product page**



The PROLIGHTS Logo, PROLIGHTS names and all other trademark in this document pertaining to PROLIGHTS services or PROLIGHTS product are trademarks OWNED or licensed by Music & Lights S.r.l., its affiliates, and subsidiaries. PROLIGHTS is a registered trademark by Music & Lights S.r.l. All right reserved. Music & Lights – Via A. Olivetti, snc - 04026 - Minturno (LT) ITALY.

# INDEX

<b>SAFETY INFORMATION</b> .....	<b>2</b>
<b>1 - PACKAGING</b> .....	<b>05</b>
PACKAGE CONTENT .....	05
OPTIONAL ACCESSORIES .....	05
<b>2 - TECHNICAL DRAWING</b> .....	<b>06</b>
<b>3 - INSTALLATION</b> .....	<b>07</b>
MOUNTING .....	07
<b>4 - PRODUCT OVERVIEW</b> .....	<b>08</b>
<b>5 - CONNECTION TO THE MAINS SUPPLY</b> .....	<b>09</b>
<b>6 - DMX CONNECTION</b> .....	<b>10</b>
CONNECTION OF THE CONTROL SIGNAL: DMX LINE .....	10
INSTRUCTIONS FOR A RELIABLE DMX CONNECTION .....	10
CONNECTION DAISY CHAIN OF THE DMX LINE .....	10
DMX ADDRESSING .....	11
<b>7 - RDM FUNCTIONS</b> .....	<b>11</b>
<b>8 - OPERATION VIA DATAMASTER</b> .....	<b>12</b>
RDM SETTING .....	12
STAND ALONE FUNCTION .....	13
<b>9 - DMX CHARTS</b> .....	<b>14</b>
<b>10 - ACCESSORIES INSTALLATION</b> .....	<b>16</b>
LENS (CODE S27QLENS10-15-25-45) .....	16
LIGHT DIFFUSION FILTER (CODE A15QFILTER) .....	17
BARN DOOR (CODE A15QBD - OPTIONAL) .....	18
<b>11 - MAINTENANCE</b> .....	<b>19</b>
MAINTENANCE AND CLEANING THE PRODUCT .....	19
VISUAL CHECK OF PRODUCT HOUSING .....	19
TROUBLESHOOTING .....	20

# SAFETY INFORMATION



## WARNING!

- Please read carefully the instruction reported in this section before installing, powering, operating or servicing the product and observe the indications also for its future handling.



**This unit is not for household use, only professional applications.**



## Connection to mains supply

- The Connection to the mains supply must be carried out by a qualified electrical installer.
- Use only AC supplies 100-240V 50-60 Hz, the fixture must be electrically connected to ground (earth).
- Select the cable cross section in according with the maximum current draw of the product and the possible number of products connected at the same power line.
- The AC mains power distribution circuit must be equipped with magnetic+residual current circuit breaker protection.
- Do not connect it to a dimmer system; doing so may damage the product.



## Protection and Warning against electrical shock

- Do not remove any cover from the product, always disconnect the product from AC power before servicing.
- Ensure that the fixture is electrically connected to ground (earth). And use only a source of AC power that complies with local building and electrical codes and has both overload and ground-fault (earth-fault) protection.
- Before using the fixture, check that all power distribution equipment and cables are in perfect condition and rated for the current requirements of all connected devices.
- Isolate the fixture from power immediately if the power plug or any seal, cover, cable, or other components are damaged, defective, deformed or showing signs of overheating.
- Do not reapply power until repairs have been completed.
- Refer any service operation not described in this manual to PROLIGHTS Service team or an authorized PROLIGHTS service center.



## Installation

- Make sure that all visible parts of the product are in good visible condition before its use or installation.
- Make sure the point of anchorage is stable before positioning the projector.
- When suspending the fixture above ground level, secure it against failure of primary attachments by attaching a safety cable that is approved as a safety attachment for the weight of the fixture to the attachment point on the main frame of the product. In case the safety cable, enter in action, it needs to be replaced with a new one.
- Install the product only in well ventilated places.
- For non temporary installations, ensure that the fixture is securely fastened to a load-bearing surface with suitable corrosionresistant hardware.
- For a temporary installation with clamps, ensure that the quarter-turn fastener and/or screws are turned fully, and secured with a suitable safety cable.



## Minimum distance of illuminated objects

- The projector needs to be positioned so that the objects hit by the beam of light are at least 0.5 meters (1.64 ft) from the lens of the projector.

**T<sub>a</sub>45°C**

**Max operating ambient temperature (T<sub>a</sub>)**

- Do not operate the fixture if the ambient temperature (T<sub>a</sub>) exceeds 45 °C (113 °F).

**T<sub>a</sub>-20°C**

**Minimum operating ambient temperature (T<sub>a</sub>)**

- Do not operate the fixture if the ambient temperature (T<sub>a</sub>) is below -20 °C (-4 °F).



**Protection from burns and fire**

- The exterior of the fixture becomes hot during use. Avoid contact by persons and materials.
- Ensure that there is free and unobstructed airflow around the fixture.
- Keep flammable materials well away from the fixture
- Do not expose the front glass to sunlight or any other strong light source from any angle. Lenses can focus the sun's rays inside the fixture, creating a potential fire hazard.
- Do not attempt to bypass thermostatic switches or fuses.

**IP66**

**Permanent Outdoor use**

- This product is rated with an IP (Ingress protection) for permanent outdoor use when used and serviced according to the instruction contained in this document.
- Never use the fixture in places subject to vibrations or bumps.
- Make certain that no inflammable liquids, water or metal objects enter the fixture.
- Excessive dust, smoke fluid, and particle build up degrades performance, causes overheating and will damage the fixture.
- Damages caused by inadequate cleaning or maintenance are not covered by the product warranty.

**T<sub>c</sub>65°C**

**Temperature of the external surface**

- The surface of the fixture can reach up to 65 °C (158 °F) during operation. Avoid contact with people and materials.



**Maintenance**

- Warning! Disconnect the fixture from AC mains power and allow to cool for at least 10 minutes before handling.
- Only technicians who are authorized by PROLIGHTS or Authorised service partners are permitted to open the fixture.
- Users may carry out external cleaning, following the warnings and instructions provided, but any service operation not described in this manual must be referred to a qualified service technician.
- Important! Excessive dust, smoke fluid, and particle build up degrades performance, causes overheating and will damage the fixture. Damages caused by inadequate cleaning or maintenance is not covered by the product warranty.



**Photobiological safety**

- This device emits potentially dangerous optical radiation and is identified in the category of Risk Group 1 according to EN 62471.



**Do not stare at the operating light source**

- Do not look directly at the LED source during operation. It can be harmful to the eyes and skin.
- During Installation, operation and maintenance, be prepared for the fixture to light and move suddenly when connected to power.



#### Disposal

- This product is supplied in compliance with European Directive 2012/19/EU – Waste Electrical and Electronic Equipment (WEEE). To preserve the environment please dispose/ recycle this product at the end of its life according to the local regulation.



#### The products to which this manual refers comply with:

- 2014/35/EU - Safety of electrical equipment supplied at low voltage (LVD).
- 2014/30/EU - Electromagnetic Compatibility (EMC).
- 2011/65/EU - Restriction of the use of certain hazardous substances (RoHS).



#### The products to which this manual refers comply with:

- UL 1573 + CSA C22.2 No. 166 - Stage and Studio Luminaires and Connector Strips.



#### FCC Compliance:

- This device complies with Part 15 of the FCC Rules. Operation is subject to the following two conditions:
  1. This device may not cause harmful interference, and
  2. This device must accept any interference received, including interference that may cause undesired operation.



#### Other approvals

- The product meets the safety requirements of the certification procedures of the market in which it is placed and sold.

# 1 - PACKAGING

## PACKAGE CONTENT

- 1x ARCPD15VW;
- 1x BARE END - IP connection adapter;
- 1x 5p XLR - IP connection male adapter;
- 1x 5p XLR - IP connection female adapter;
- User Manual.

## OPTIONAL ACCESSORIES

- AWEXDC1221: ADP Signal adapter kit from AWEXDC1 series to AWEXDC2 series and vice versa.
- C6002B: Slim aluminum clamp, 200kg loading, 48-51mm tubes, M10 bolt, Black.
- RSR0630B: Steel security cable for hanging bodies, inox steel shackle, L=60 cm, black.
- AWEXAC12ADP: Power adapter from AWEXAC1 cable series to AWEXAC2 cable series.
- A15QFILTER20: 20° symmetric light diffusion filter for ARCPD15Q/VW, 11,4x18,6 cm.
- A15QFILTER30: symmetric light diffusion filter for ARCPD15Q/VW, 11,4x18,6 cm.
- A15QFILTER40: 40° symmetric light diffusion filter for ARCPD15Q/VW, 11,4x18,6 cm.
- A15QFILTER60: 60° symmetric light diffusion filter for ARCPD15Q/VW, 11,4x18,6 cm.
- A15QFILTER80: 80° symmetric light diffusion filter for ARCPD15Q/VW, 11,4x18,6 cm.
- A15QFILTER1060: 10°x60° asymmetric light diffusion filter for ARCPD15Q/VW, 11,4x18,6 cm.
- A15QFILTER3060: 30°x60° asymmetric light diffusion filter for ARCPD15Q/VW, 11,4x18,6 cm.
- A15QFILTER6010: 60°X10° asymmetric light diffusion filter for ARCPD15Q/VW, 11,4x18,6 cm.
- A15QFILTER6030: 60°X30° asymmetric light diffusion filter for ARCPD15Q/VW, 11,4x18,6 cm.
- S27QLENS10: 10° lens for SOLAR27, ARCPD27, SOLAR48, ARCPD48, ARCPD15 and ARCPD96 series.
- S27QLENS15: 15° lens for SOLAR27, ARCPD27, SOLAR48, ARCPD48, ARCPD15 and ARCPD96 series.
- S27QLENS25: 25° lens for SOLAR27, ARCPD27, SOLAR48, ARCPD48, ARCPD15 and ARCPD96 series.
- S27QLENS45: 45° lens for SOLAR27, ARCPD27, SOLAR48, ARCPD48, ARCPD15 and ARCPD96 series.
- A15QBD: Black barn door 4 directional flaps to adjust the light beam, ARCPD15Q/VW.
- DATAMASTER: RDM/DMX tool, cable tester, 5p XLR connectors, pouch, charging cable, XLR adapters.
- AWEXAC1L03: IP67 power extension cable for outdoor architectural projectors, L.03 m.
- AWEXAC1L05: IP67 power extension cable for outdoor architectural projectors, L.05 m.
- AWEXDC1L10: IP67 DMX extension cable for outdoor architectural projectors, L.10 m.
- AWEXAC1L20: IP67 power extension cable for outdoor architectural projectors, L.20 m.
- AWEXDC1L03: IP67 DMX extension cable for outdoor architectural projectors, L.03 m.
- AWEXDC1L05: IP67 DMX extension cable for outdoor architectural projectors, L.05 m.
- AWEXAC1L10: IP67 power extension cable for outdoor architectural projectors, L.10 m.
- AWEXDC1L20: IP67 DMX extension cable for outdoor architectural projectors, L.20 m.
- UPBOX1UP5: Firmware uploader kit, USB IN, 5pin XLR DMX OUT, USB OUT.

## 2 - TECHNICAL DRAWING

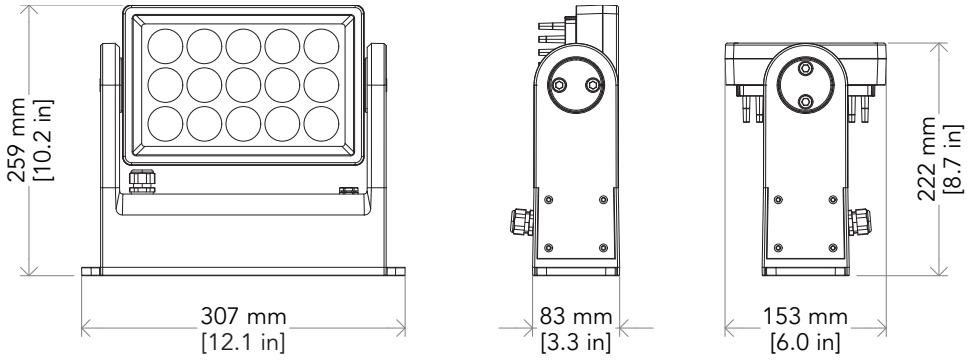

Weight: 6.3 kg - 13.89 lbs

Fig. 01



# 3 - INSTALLATION

## MOUNTING

Check that the supporting structure can safely bear the weight of all installed fixtures, clamps, cables, auxiliary equipment, etc. and complies with locally applicable regulations.

For temporary installation when suspending the fixture above ground level, secure it against failure of primary attachments by attaching a safety wire that is approved as a safety attachment for the weight of the fixture to an anchor point on the product main frame.

For fixed installation use M8 bolts.

Do not use removable parts or weak anchors for secondary attachment.

Warning! When clamping the fixture to a truss or other structure at any angle, use clamps of half-coupler type. Do not use any type of clamp that does not completely encircle the structure when fastened.

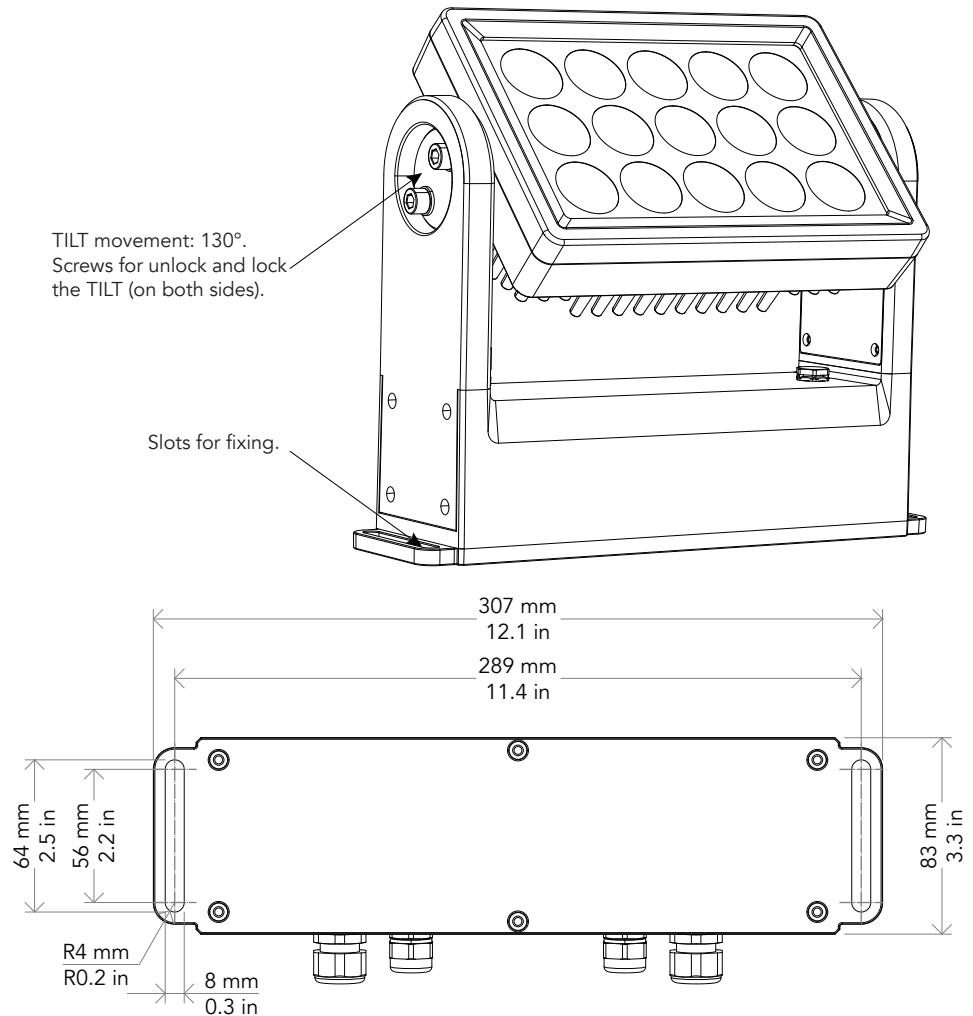

Fig. 02

## 4 - PRODUCT OVERVIEW

1. POWER IN: for connection to a mains (100-240V~/50-60Hz). The max power consumption is 120W.
2. DMX IN (3-pole): 1 = GND, 2 = sign-, 3 = sign+.
3. DMX OUT (3-pole): 1 = GND, 2 = sign-, 3 = sign+.
4. POWER OUT: power output for connection of multiple units in series.

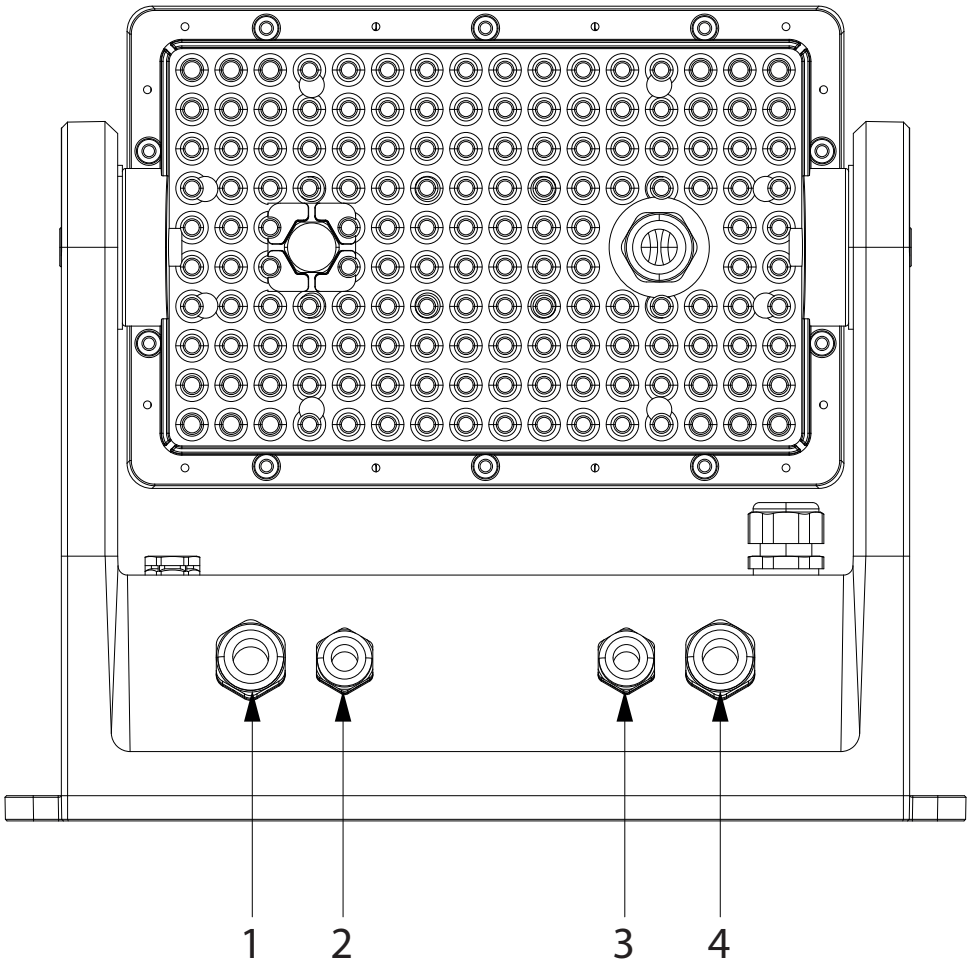

Fig. 03

# 5 - CONNECTION TO THE MAINS SUPPLY

**WARNING:** For protection from electric shock, the fixture must be earthed!

The product is equipped with auto-switching power supply that automatically adjusts to any 50-60Hz AC power source from 100-240 Volts.

If you need to install a power plug on the power cable to allow connection to power outlets, install a grounding-type (earthed) plug, following the plug manufacturer's instructions. If you have any doubts about proper installation, consult a qualified electrician.

The max power consumption is 145W.

You can link up to 14 at 230 V. Never exceed this number. Power linking cords can be purchased separately.

Core (EU)	Core (US)	Connection	Plug terminal marking
Brown	Black	Live	L
Blue	White	Neutral	N
Yellow+green	Green	Earth	E

## MALE POWER IP67 CONNECTOR



## FEMALE POWER IP67 CONNECTOR



Fig. 04

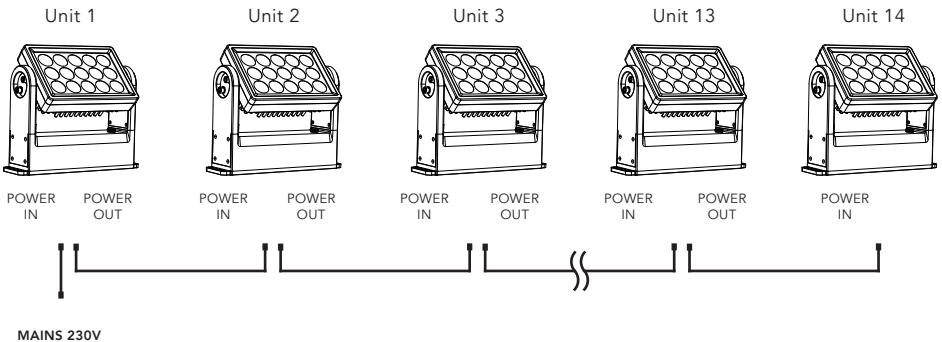

**NOTE:** when not using the Power output connectors, you must seal the cable ends with the supplied caps.

Fig. 05 - Example configuration (Output at 230 V)

# 6 - DMX CONNECTION

## CONNECTION OF THE CONTROL SIGNAL: DMX LINE

The product has connectors for DMX input and output.  
The default pin-out on both connectors is as the following diagram:

**DMX - INPUT  
IP67 CONNECTOR**

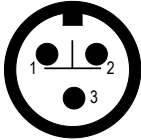

Pin1 : GND - Shield  
Pin2 : - Signal  
Pin3 : + Signal

**DMX - OUTPUT  
IP67 CONNECTOR**

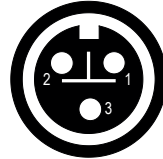

Fig. 06

## INSTRUCTIONS FOR A RELIABLE DMX CONNECTION

Use shielded twisted-pair cable designed for RS-485 devices: standard microphone cable cannot transmit control data reliably over long runs. 24 AWG cable is suitable for runs up to 300 meters (1000 ft). Heavier gauge cable and/or an amplifier is recommended for longer runs. To split the data link into branches, use splitter-amplifiers in the connection line. Do not overload the link. **Up to 20 devices may be connected on a serial link and 11 units through RDM or DATAMASTER.**

**NOTE: To connect the unit to your DMX network, it is necessary to use the adapters XLR 5 pin-IP67 signal connector, supplied with this product.**

## CONNECTION DAISY CHAIN OF THE DMX LINE

Connect the DMX data output from the DMX source to the product DMX input (male connector). Run the data link from the product DMX output (female connector) connector to the DMX input of the next fixture. Terminate the data link by connecting a 120 Ohm signal termination. The termination is prepared by 120Ω 1/4 W resistor between pins 2 and 3 of the male DMX connector. Install a DMX termination plug on the last fixture on the link. If a splitter is used, terminate each branch of the link.

**NOTE: when not using the DMX input or DMX output connectors, you must seal the cable ends with the supplied caps.**

The following diagram shows the DMX connection:

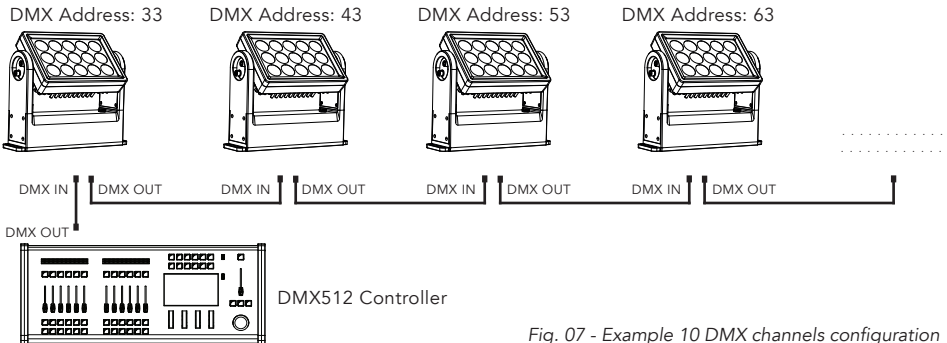

Fig. 07 - Example 10 DMX channels configuration

## DMX ADDRESSING

In order to start controlling the product via DMX, the first step is to select a DMX address, also known as the start channel, this is the first channel used to receive instructions from a DMX controller. If you wish to control the product individually, it is necessary to assign a different starting address channel to each fixture.

The number of channels occupied from the product depends on the DMX mode selected, so always verify the DMX Mode before start addressing.

If you assign two fixtures the same address, they will be executing the same behaviour. Selecting the same address to multiple fixtures can be useful for diagnostic purposes and symmetrical control.

DMX addressing is limited to make it impossible to set the DMX address so high that you are left without enough control channels for the product.

Set the fixture's DMX address by RDM with the DATAMASTER.

## 7 - RDM FUNCTIONS

The product can communicate using RDM (Remote Device Management) protocol over a DMX512 Networks.

RDM is a bi-directional communications protocol for use in DMX512 control systems, it is the open standard for DMX512 device configuration and status monitoring.

The RDM protocol allows data packets to be inserted into a DMX512 data stream without affecting existing non-RDM equipment. It allows a console or dedicated RDM controller to send commands to and receive messages from specific fixtures.

The PIDs in the following tables are supported in the product.

Parameter	PID	GET	SET
DEVICE_INFO	0x0060	x	
DEVICE_MODEL_DESCRIPTION	0x0080	x	
MANUFACTURER_LABEL	0x0081	x	
DEVICE_LABEL	0x0082	x	x
FACTORY_DEFAULTS	0x0090	x	x
SOFTWARE_VERSION_LABEL	0x00C0	x	
DMX_PERSONALITY	0x00E0	x	x
DMX_PERSONALITY_DESCRIPTION	0x00E1	x	
DMX_START_ADDRESS	0x00F0	x	x
DIMMER_INFO	0x00F0		
CURVE	0x0343	x	x
CURVE_DESCRIPTION	0x0344	x	x
SENSOR_VALUE	0x0201	x	x
IDENTIFY_DEVICE	0x1000	x	
DMX FAULT(0:BLACKOUT,1:HOLD,2:STANDALONE)	0x8200	x	x
MASTER/SLAVE (0:MST DMX; 1:MST NO DMX; 2:SLAVE)	0x8201	x	x
STAND ALONE MODE (0:EFFECT; 1:STATIC; 2:CCT; 3:MANUAL)	0x8202	x	x
EFFECTS (0-9)	0x8203	x	x
EFFECT SPEED (0-255)	0x8217	x	x
STATIC COLORS (0-2)	0x82C9	x	x
WHITE PRESETS (0-9)	0x82CA	x	x
MANUAL WW(000-255)	0x82CB	x	x
MANUAL CW(000-255)	0x82CC	x	x
UNO (0:STATIC; 1:CCT; 2:MANUAL)	0x8211	x	x
WH. CAL. WW(000-255)	0x82EC	x	x
WH. CAL CW(000-255)	0x8209	x	x
CURRENT HOURS(00000-65535)	0x82BE	x	x
POWER CONSUMPTION(AC 220V)	0x82BF	x	x
MAINTENANCE TIME(ALERT PERIOD:10-300)	0x82C0	x	x
MAINTENANCE TIME(ELAPSED TIME:00-ALERT PERIOD)	0x82C1	x	x
ERROR MESSAGES (???)	0x82C2	x	x
CLEAN ALL DATA(0:NO,1:YES)	0x82C3	x	x

## 8 - OPERATION VIA DATAMASTER

The unit uses a DATAMASTER for configuration purposes. The diagram below shows how to connect the DATAMASTER to this product. This connection will control multiple products at the same time. To set different Stand Alone mode on different product, you must connect the DATAMASTER to each product, individually.

However, by using the DATAMASTER, you may address each product in the daisy chain to a different DMX address by using the RDM function without the need connect to each individual product.

Important: The DATAMASTER must be used to configure this product.

MUSIC & LIGHTS suggests that you connect no more than 11 units in this mode and keep the total distance to less than 60 m (197 ft). Otherwise, you might need to use an RDM optically isolated signal amplifier.

### RDM SETTING

To set the RDM functions with the DATAMASTER follow these steps:

- Turn on the DATAMASTER;
- Select the "RDM" function;
- Wait the discovering of all units;
- Select the desired unit and press ENTER button;
- Change the value of the desired function.

The following chart describes the RDM menu tree of the product, the terms shown in **BOLD** indicates the default settings.

	MENU*		
1	DMX_START_ADDRESS	001 - 512	
2	DMX_PERSONALITY	1CH 2CH 3CH 4CH 9CH	To choose the DMX mode.
3	CURVE	0:LINEAR 1:S-CURVE <b>2:SQUARE LAW</b> 3:INVERSE SQUARE LAW	To choose the dimmer curve.
4	OUTPUT_RESPONSE_TIME	<b>0:AUTO</b> 1:FAST 2:MEDIUM 3:SLOW	To choose the dimmer speed.
5	MODULATION_FREQUENCY	0:600Hz <b>1:1200Hz</b> 2:2000Hz 3:4000Hz 4:6000Hz 5:25kHz	Select PWM frequency.

## STAND ALONE FUNCTION

To set the STAND ALONE you must follow the below steps with DATAMASTER:

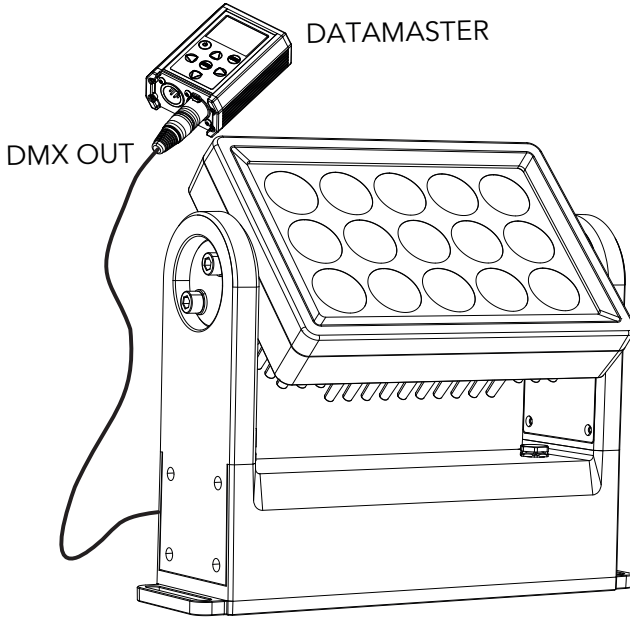

Fig. 08

- Connect only one projector to the DATAMASTER;
- Select the second function "STAND ALONE";
- Select "Manual Color" or "Effect" function;
- Select "Head 1";
- Select the desired color or effect with speed.

The projector where is setted the STAND ALONE values is a "MASTER" projector.

If there isn't the DMX controller or the DMX missing this projector will send his STAND ALONE value on the DMX line.

On others units that will be connected to the same DMX line must NOT be setted the STAND ALONE, they will be "SLAVE" and they will follow the DMX of the MASTER.

# 9 - DMX CHARTS

RDM Model ID: 0xD090  
 RDM Personality ID List

ID	DMX Mode	Footprint
1	1 Ch	1
2	2 Ch	2
3	3 Ch	3
4	4 Ch	4
5	9 Ch	9

CH	1CH	2CH	3CH	4CH	9CH
1	DIMMER	DIMMER	WARM WHITE	DIMMER	DIMMER
2		CCT	COLD WHITE	DIMMER FINE	DIMMER FINE
3			DIMMER FADE	CCT	STROBE
4				DIMMER FADE	CCT
5					CROSSFADE
6					WARM WHITE
7					COLD WHITE
8					DIMMER FADE
9					CONTROL



1CH	2CH	3CH	4CH	9CH	FUNCTION	DMX Value	Default
1	1		1	1	<b>DIMMER</b> 0~100%	000 ÷ 255	000
			2	2	<b>DIMMER FINE</b> 0~100%	000 ÷ 255	000
				3	<b>STROBE</b> Close Strobe from slow to fast Open Pulse in from slow to fast Open Pulse out from slow to fast Open Randon from slow to fast Open	000 ÷ 001 002 ÷ 062 063 ÷ 064 065 ÷ 125 126 ÷ 127 128 ÷ 188 189 ÷ 190 191 ÷ 251 252 ÷ 255	255
	2		3	4	<b>CCT</b> Linear from 2700K to 6500K	000 ÷ 255	000
				5	<b>CROSSFADE FROM CCT TO WWCW</b> 0~100%	000 ÷ 255	000
		1		6	<b>WARM WHITE</b> 0~100%	000 ÷ 255	000
		2		7	<b>COLD WHITE</b> 0~100%	000 ÷ 255	000
		3	4	8	<b>DIMMER FADE</b> Preset dimmer speed from display menu Dimmer speed mode off Dimmer speed mode 1 (fast speed) Dimmer speed mode 2 (middle speed) Dimmer speed mode 3 (slow speed)	000 ÷ 051 052 ÷ 101 102 ÷ 152 153 ÷ 203 204 ÷ 255	000
				9	<b>CONTROL</b> NO FUNCTION DIMMER CURVE LINEAR DIMMER CURVE S-CURVE DIMMER CURVE SQUARE LAW DIMMER CURVE INVERSE SQUARE LAW DIMMER SPEED AUTO DIMMER SPEED FAST DIMMER SPEED MEDIUM DIMMER SPEED SLOW LED FREQUENCY 600HZ LED FREQUENCY 1200HZ LED FREQUENCY 2000HZ LED FREQUENCY 4000HZ LED FREQUENCY 6000HZ LED FREQUENCY 25KHZ DMX FAULT HOLD DMX FAULT BLACKOUT DMX FAULT STAND ALONE STAND ALONE MASTER DMX STAND ALONE MASTER NO DMX STAND ALONE SLAVE STAND ALONE EFFECTS STAND ALONE STATIC COLORS STAND ALONE WHITE PRESETS STAND ALONE MANUAL COLORS INVERT MAPPING ON INVERT MAPPING OFF Reserved FACTORY DEFAULT OF CONTROL FUNCTIONS	0 ÷ 1 2 ÷ 3 4 ÷ 5 6 ÷ 7 8 ÷ 9 10 ÷ 11 12 ÷ 13 14 ÷ 15 16 ÷ 17 18 ÷ 19 20 ÷ 21 22 ÷ 23 24 ÷ 25 26 ÷ 27 28 ÷ 29 30 ÷ 31 32 ÷ 33 34 ÷ 35 36 ÷ 37 38 ÷ 39 40 ÷ 41 42 ÷ 43 44 ÷ 45 46 ÷ 47 48 ÷ 49 50 ÷ 51 52 ÷ 53 54 ÷ 253 254 ÷ 255	000

## 10 - ACCESSORIES INSTALLATION

LENS (CODE S27QLENS10-15-25-45)

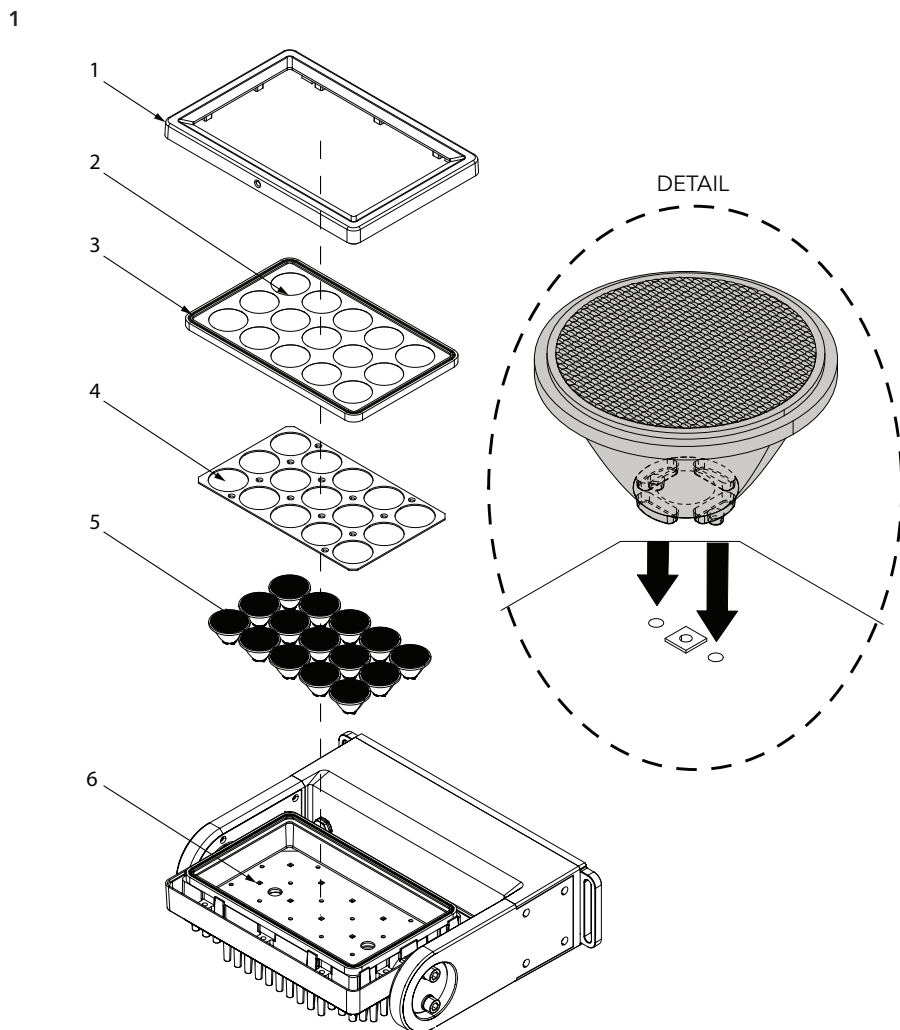

**WARNING:** never touch the LEDs.

1. Remove the front cover (1) by loosening the screws. Then remove the front glass (2), rubber seal (3), lens holder (4) and the lens (5)
2. Replace the lenses by inserting the two pins on the back of the lens (DETAIL) with the holes provided on the PCB LED (5).

NOTE: to reassemble the lenses, reverse the procedure.

NOTE: it is recommended to tighten the front cover screws carefully so as to guarantee the correct IP degree.

Fig. 09

## LIGHT DIFFUSION FILTER (CODE A15QFILTER)

1

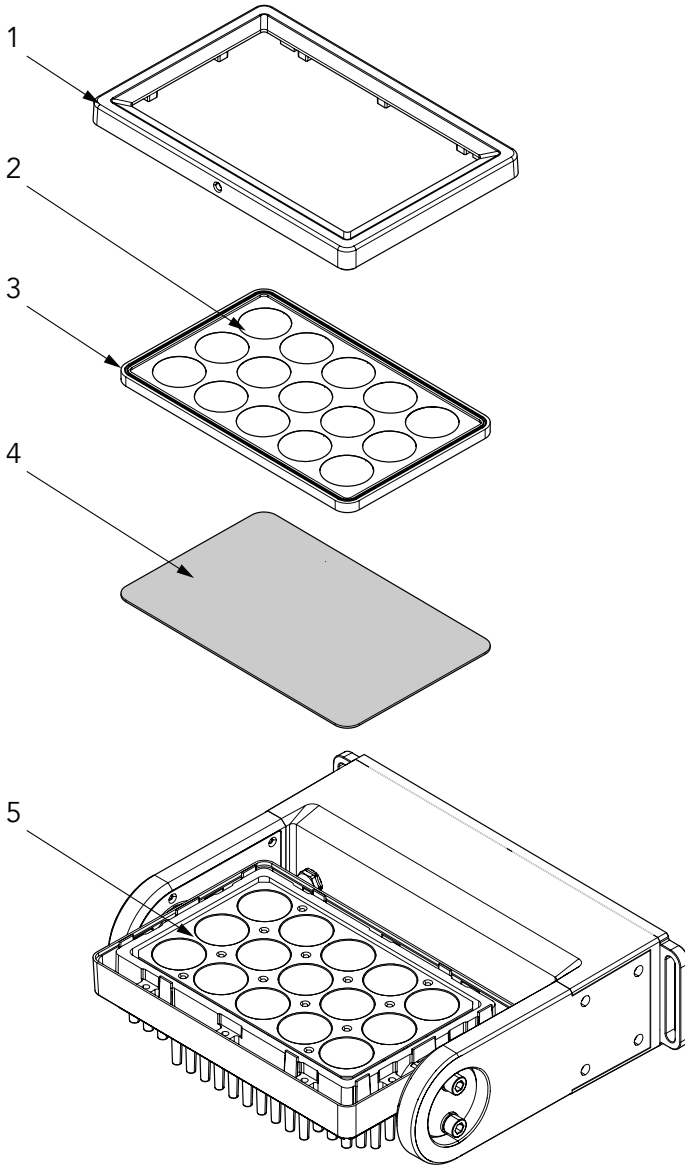

WARNING: never touch the LEDs.

1. Remove the front cover (1) by loosening the screws. Then remove the front glass (2) and the rubber seal (3). Place the light diffusion filter (4) on the lenses.

NOTE: to remove the light diffusion filter, reverse the procedure.

Fig. 10

## BARN DOOR (CODE A15QBD - OPTIONAL)

1

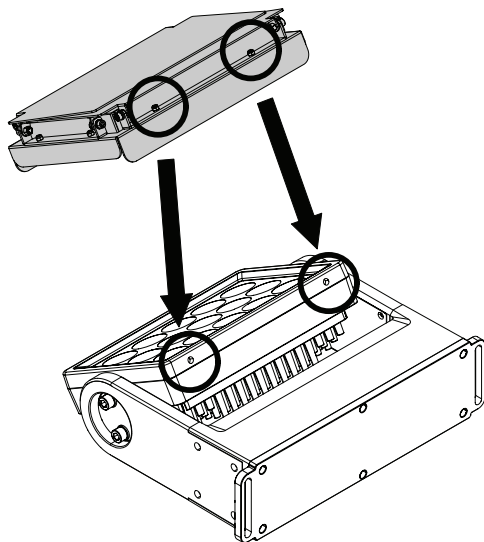

2

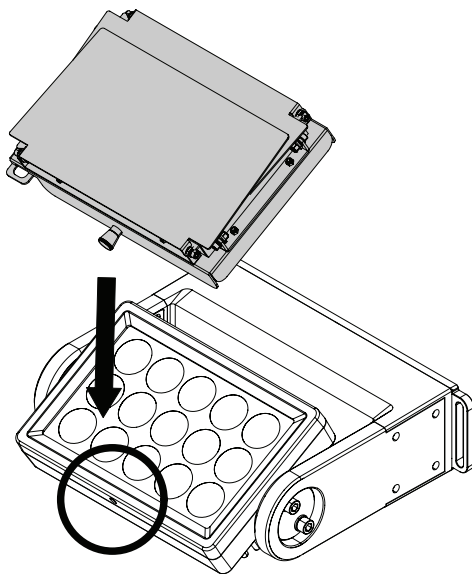

Insert the two marked pin on down edge of the barn door into the holes provided on the unit (1) and positioning the spring pin on the hardware into the hole provided on the top (2).

3

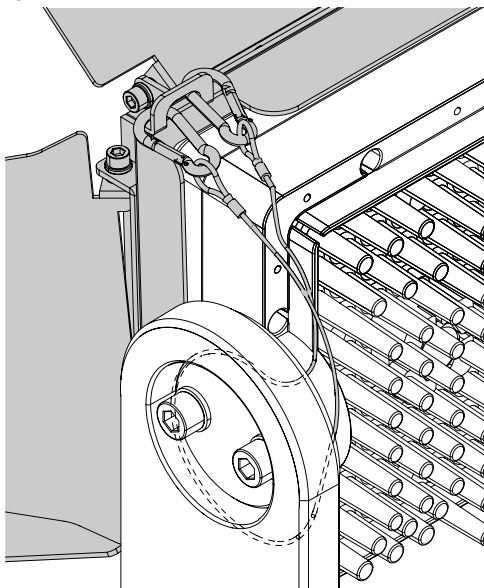

4

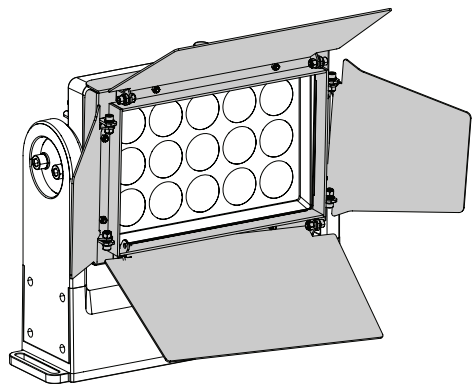

Hook the safety cable (3) and adjust the angle of the four leaves (4).

Fig. 11

# 11 - MAINTENANCE

## MAINTENANCE AND CLEANING THE PRODUCT

**WARNING:** Disconnect from the mains before starting any maintenance work

It is recommended to clean the front at regular intervals, from impurities caused by dust, smoke, or other particles to ensure that the light is radiated at maximum brightness.

- For cleaning, disconnect the main plug from the socket. Use a soft, clean cloth moistened with a mild detergent. Then carefully wipe the part dry. For cleaning other housing parts use only a soft, clean cloth. Never use a liquid, it might penetrate the unit and cause damage to it.
- The user must clean the product periodically to maintain optimum performance and cooling. The user may also upload firmware (product software) to the fixture via the DMX signal input port using firmware and instructions from MUSIC & LIGHTS.
- The frequency of such maintenance operations is to be performed according to various factors, such as the amount of the use and the condition of the installation environment. It is recommended that the product is subject to annual service by a qualified technician for special maintenance involving at least the following procedures:
- General cleaning of internal parts.
- All other service operations on the product must be carried out by MUSIC & LIGHTS, its approved service agents or trained and qualified personnel.
- Use only accessories approved by MUSIC & LIGHTS.

## VISUAL CHECK OF PRODUCT HOUSING

- The parts of the product cover/housing and glass must be checked for eventual damages and breaking, do not use the product until the damaged part will be replaced.
- Cracks or another damages of the cover/housing parts can be caused by the product transportation or manipulation and also ageing process may influence materials.
- This checking is necessary for both fixed installations and preparing product for renting. Any free moving parts inside of the product, cracked cover/housing or any part of front glass not sitting properly in place need to be immediately replaced.

## TROUBLESHOOTING

Problems	Possible causes	Checks and remedies
Product doesn't power ON	<ul style="list-style-type: none"> <li>No power to the product.</li> </ul>	<ul style="list-style-type: none"> <li>Check that power is switched ON and cables are plugged in.</li> </ul>
	<ul style="list-style-type: none"> <li>Fuse blown or internal fault.</li> </ul>	<ul style="list-style-type: none"> <li>Check if the Fuse is intact and eventually replace it if necessary.</li> <li>Contact the MUSIC &amp; LIGHTS Service or authorized service partner. Do not remove parts and/or covers, or carry out any repairs or service that are not described in this Safety and User Manual unless you have both authorization from MUSIC &amp; LIGHTS and the service documentation.</li> </ul>
Product reset correctly but does not respond correctly to the controller.	<ul style="list-style-type: none"> <li>Bad signal connection.</li> </ul>	<ul style="list-style-type: none"> <li>Inspect connections and cables. Fix eventual bad connections. Repair or replace damaged cables.</li> </ul>
	<ul style="list-style-type: none"> <li>Signal connection not terminated.</li> </ul>	<ul style="list-style-type: none"> <li>Insert DMX termination plug in signal output socket of the last product on the signal line.</li> </ul>
	<ul style="list-style-type: none"> <li>Incorrect addressing of the product.</li> </ul>	<ul style="list-style-type: none"> <li>Check the product address and control settings.</li> </ul>
	<ul style="list-style-type: none"> <li>One of the product is defective and is corrupting the signal transmission on the signal line.</li> </ul>	<ul style="list-style-type: none"> <li>Unplug the XLR in and out connectors and connect them directly together to bypass one product at a time until normal operation is regained. Once found the error, have that fixture serviced by a qualified technician.</li> </ul>
Timeout error after fixture reset.	<ul style="list-style-type: none"> <li>One or more hardware components requires mechanical adjustments.</li> </ul>	<ul style="list-style-type: none"> <li>Check product stored error messages for more information. Contact MUSIC &amp; LIGHTS Service or an authorized service partner.</li> </ul>
Mechanical effect loses position	<ul style="list-style-type: none"> <li>Mechanical hardware require cleaning, adjustment or lubrication.</li> </ul>	<ul style="list-style-type: none"> <li>Check product stored error messages for more information. Contact MUSIC &amp; LIGHTS Service or an authorized service partner.</li> </ul>
Light output turn OFF Intermittently	<ul style="list-style-type: none"> <li>Fixture is too hot.</li> </ul>	<ul style="list-style-type: none"> <li>Check product stored error messages.</li> <li>Allow product to cool.</li> <li>Clean the product and airflow filters.</li> <li>Reduce ambient temperature.</li> </ul>
	<ul style="list-style-type: none"> <li>Hardware failure (temperature sensor, fans, Light source...).</li> </ul>	<ul style="list-style-type: none"> <li>Check product stored error messages for more information. Contact.</li> <li>MUSIC &amp; LIGHTS Service or an authorized service partner.</li> </ul>
General low light intensity	<ul style="list-style-type: none"> <li>Dirty lens assembly.</li> </ul>	<ul style="list-style-type: none"> <li>Clean the fixture regularly.</li> </ul>
	<ul style="list-style-type: none"> <li>Dirty or damaged filters.</li> </ul>	<ul style="list-style-type: none"> <li>Install lens assembly properly.</li> </ul>

Contact an authorized service center in case of technical problems or not reported in the table can not be resolved by the procedure given in the table.





**PROLIGHTS** is a trademark of  
**MUSIC & LIGHTS S.r.l.**  
**musiclights.it**

Via A.Olivetti snc  
04026 - Minturno (LT) ITALY  
Tel: +39 0771 72190

**prolights.it**  
support@prolights.it