



ARCSPOT S FC

IP66 Spot featuring 1300 lumen with 7x
4W RGB+WarmWhite source, 10° native



USER MANUAL

Thank you for choosing PROLIGHTS

Please note that every PROLIGHTS product has been designed in Italy to meet quality and performance requirements for professionals and designed and manufactured for the use and application as shown in this document.

Any other use, if not expressly indicated, could compromise the good condition/operation of the product and/or be a source of danger.

This product is meant for professional use. Therefore, commercial use of this equipment is subject to the respectively applicable national accident prevention rules and regulations.

Features, specifications and appearance are subject to change without notice. Music & Lights S.r.l. and all affiliated companies disclaim liability for any injury, damage, direct or indirect loss, consequential or economic loss or any other loss occasioned by the use of, inability to use or reliance on the information contained in this document.

Product user manual can be downloaded from the website www.prolights.it, or can be inquired to the official PROLIGHTS distributors of your territory (https://www.prolights.it/sales_network.html).

Scanning the below **QR Code**, you will access the download area of the product page, where you can find a broad set of always updated technical documentation: specifications, user manual, technical drawings, photometrics, personalities, fixture firmware updates.



Visit the download area
of the product page



The PROLIGHTS Logo, PROLIGHTS names and all other trademark in this document pertaining to PROLIGHTS services or PROLIGHTS product are trademarks OWNED or licensed by Music & Lights S.r.l., its affiliates, and subsidiaries. PROLIGHTS is a registered trademark by Music & Lights S.r.l. All right reserved. Music & Lights – Via A. Olivetti, snc - 04026 - Minturno (LT) ITALY.

INDEX

SAFETY INFORMATION	02
1 - PACKAGING	05
PACKAGE CONTENT	05
OPTIONAL ACCESSORIES	05
2 - TECHNICAL DRAWING	05
3 - INSTALLATION	06
MOUNTING	06
4 - PRODUCT OVERVIEW	07
5 - CONNECTION TO THE MAINS SUPPLY	08
6 - START UP	08
CONNECT AND DISCONNECT POWER FROM THE PRODUCT	08
7 - DMX CONNECTION	09
CONNECTION OF THE CONTROL SIGNAL: DMX LINE	09
INSTRUCTIONS FOR A RELIABLE DMX CONNECTION	09
CONNECTION DAISY CHAIN OF THE DMX LINE	09
CONNECTION OF THE DMX LINE	10
CONSTRUCTION OF THE DMX TERMINATION	10
8 - OPERATION VIA DATAMASTER	11
RDM SETTING	11
9 - RDM MENU STRUCTURE	12
10 - RDM FUNCTIONS	14
11 - DMX CHARTS	16
12 - ACCESSORIES INSTALLATION	23
HALF SNOOT (CODE ARSHSNOOTGY/WH - OPTIONAL)	23
HONEYCOMB LOUVRE (CODE ARSHLOUVREGY/WH - OPTIONAL)	24
LENS (CODE ASLENS15/25/45 - OPTIONAL)	25
13 - MAINTENANCE	28
MAINTENANCE AND CLEANING THE PRODUCT	28
VISUAL CHECK OF PRODUCT HOUSING	28
14 - TEST OF IP66 RATING	29

SAFETY INFORMATION



WARNING!

- See <https://www.prolights.it/product/ARCSPOTSEFC#download> for installation instructions.
- Please read carefully the instruction reported in this section before installing, powering, operating or servicing the product and observe the indications also for its future handling.



This unit is not for household and residential use, only professional applications.



Connection to mains supply

- The Connection to the mains supply must be carried out by a qualified electrical installer.
- Use only AC supplies 100-240V 50-60 Hz, the fixture must be electrically connected to ground (earth).
- Select the cable cross section in according with the maximum current draw of the product and the possible number of products connected at the same power line.
- The AC mains power distribution circuit must be equipped with magnetic+residual current circuit breaker protection.
- Do not connect it to a dimmer system; doing so may damage the product.



Protection and Warning against electrical shock

- Do not remove any cover from the product, always disconnect the product from AC power before servicing.
- Ensure that the fixture is electrically connected to ground (earth). And use only a source of AC power that complies with local building and electrical codes and has both overload and ground-fault (earth-fault) protection.
- Before using the fixture, check that all power distribution equipment and cables are in perfect condition and rated for the current requirements of all connected devices.
- Isolate the fixture from power immediately if the power plug or any seal, cover, cable, or other components are damaged, defective, deformed or showing signs of overheating.
- Do not reapply power until repairs have been completed.
- Refer any service operation not described in this manual to PROLIGHTS Service team or an authorized PROLIGHTS service center.



Installation

- Make sure that all visible parts of the product are in good visible condition before its use or installation.
- Make sure the point of anchorage is stable before positioning the projector.
- When suspending the fixture above ground level, secure it against failure of primary attachments by attaching a safety cable that is approved as a safety attachment for the weight of the fixture to the attachment point on the main frame of the product. In case the safety cable, enter in action, it needs to be replaced with a new one.
- Install the product only in well ventilated places.
- For non temporary installations, ensure that the fixture is securely fastened to a load-bearing surface with suitable corrosionresistant hardware.
- For a temporary installation with clamps, ensure that the quarter-turn fastener and/or screws are turned fully, and secured with a suitable safety cable.

⌀ 0,5 m

Minimum distance of illuminated objects

- TBD

T_a45°C

Max operating ambient temperature (T_a)

- TBD

T_a-10°C

Minimum operating ambient temperature (T_a)

- TBD



Protection from burns and fire

- The exterior of the fixture becomes hot during use. Avoid contact by persons and materials.
- Ensure that there is free and unobstructed airflow around the fixture.
- Keep flammable materials well away from the fixture
- Do not expose the front glass to sunlight or any other strong light source from any angle. Lenses can focus the sun's rays inside the fixture, creating a potential fire hazard.
- Do not attempt to bypass thermostatic switches or fuses.

IP65

Permanent Outdoor use

- This product is rated with an IP (Ingress protection) for permanent outdoor use when used and serviced according to the instruction contained in this document.
- Never use the fixture in places subject to vibrations or bumps.
- Make certain that no inflammable liquids, water or metal objects enter the fixture.
- Excessive dust, smoke fluid, and particle build up degrades performance, causes overheating and will damage the fixture.
- Damages caused by inadequate cleaning or maintenance are not covered by the product warranty.

T_c70°C

Temperature of the external surface

- TBD



Maintenance

- Warning! Disconnect the fixture from AC mains power and allow to cool for at least 10 minutes before handling.
- Only technicians who are authorized by PROLIGHTS or Authorised service partners are permitted to open the fixture.
- Users may carry out external cleaning, following the warnings and instructions provided, but any service operation not described in this manual must be referred to a qualified service technician.
- Important! Excessive dust, smoke fluid, and particle build up degrades performance, causes overheating and will damage the fixture. Damages caused by inadequate cleaning or maintenance is not covered by the product warranty.



Photobiological safety

- TBD



Do not stare at the operating light source

- TBD

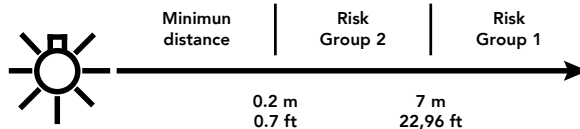



Disposal

- This product is supplied in compliance with European Directive 2012/19/EU – Waste Electrical and Electronic Equipment (WEEE). To preserve the environment please dispose/ recycle this product at the end of its life according to the local regulation.



The products to which this manual refers comply with:

- 2014/35/EU - Safety of electrical equipment supplied at low voltage (LVD).
- 2014/30/EU - Electromagnetic Compatibility (EMC).
- 2011/65/EU - Restriction of the use of certain hazardous substances (RoHS).



The products to which this manual refers comply with:

- UL 1573 + CSA C22.2 No. 166 - Stage and Studio Luminaires and Connector Strips.
- UL 1012 + CSA C22.2 No. 107.1 - Standard for power units other than class 2.



FCC Compliance:

- This device complies with Part 15 of the FCC Rules. Operation is subject to the following two conditions:
 1. This device may not cause harmful interference, and
 2. This device must accept any interference received, including interference that may cause undesired operation.

1 - PACKAGING

PACKAGE CONTENT

- 1x ARCSPOTSFC.
- User Manual.

OPTIONAL ACCESSORIES

Check the updated accessories list, description and informations of the product at the following link:
<https://www.prolights.it/product/ARCSPOTSFC#accessories>

2 - TECHNICAL DRAWING

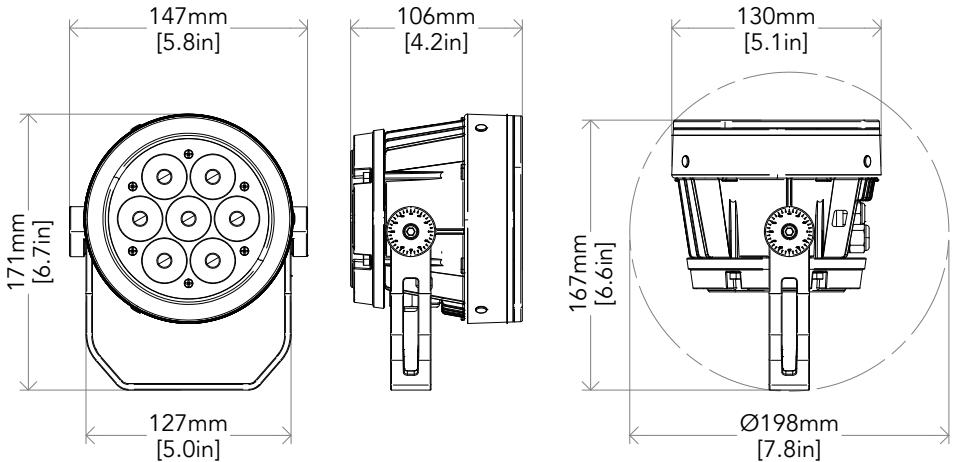

Weight: 1,3 kg - 2,86 lbs

Fig. 01

3 - INSTALLATION

MOUNTING

Check that the supporting structure can safely bear the weight of all installed fixtures, clamps, cables, auxiliary equipment, etc. and complies with locally applicable regulations.

When suspending the fixture above ground level, secure it against failure of primary attachments by attaching a safety wire that is approved as a safety attachment for the weight of the fixture to an anchor point on the product main frame.

Do not use removable parts or weak anchors for secondary attachment.

Warning! When clamping the fixture to a truss or other structure at any angle, use clamps of half-coupler type. Do not use any type of clamp that does not completely encircle the structure when fastened.

NOTE: In external installations it is advisable to mount the product with the cables facing downwards to avoid water or humidity deposits which can compromise functionality in the long term.

C6002
clamp

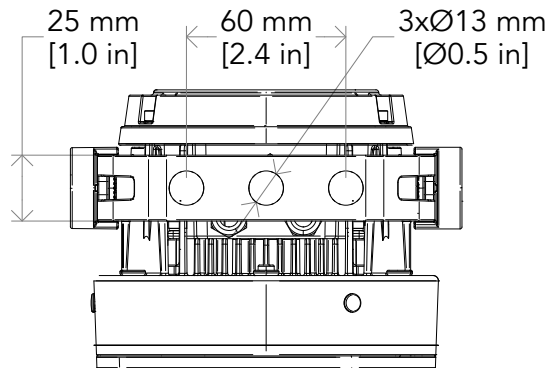
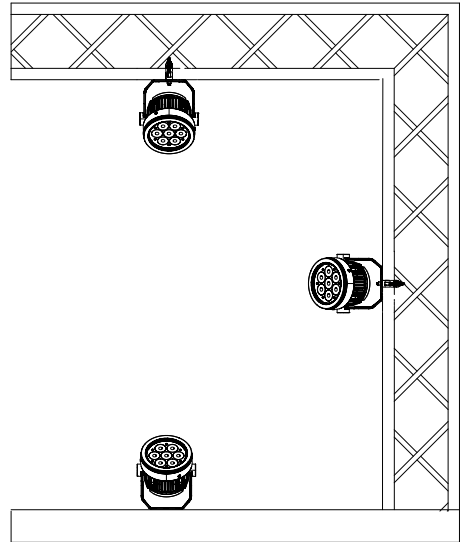
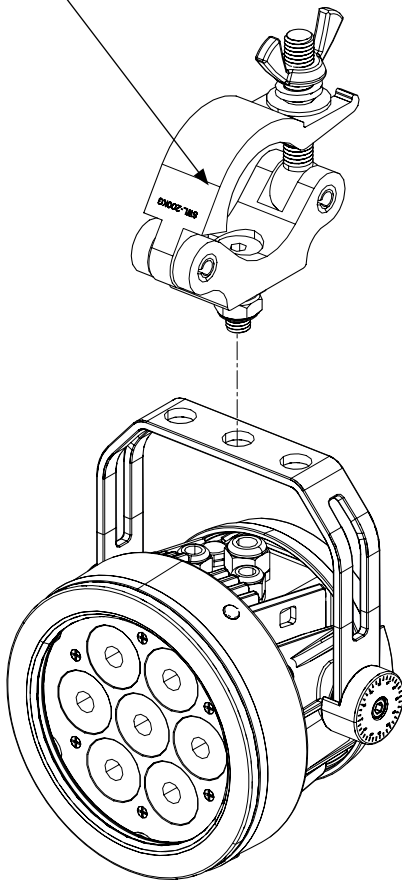

Fig. 02

4 - PRODUCT OVERVIEW

1. ADJUSTABLE YOKE: to install the fixture.
2. SAFETY EYES: to attach safety cable.
3. GORE VALVE.
4. DMX IN (4-p XLR): 1 = GND, 2 = sign-, 3 = sign+, 4 N/C, 5.
5. POWER IN: for connection to the Mains 100-240V~/50-60Hz.
6. DMX OUT (4-p XLR): 1 = GND, 2 = sign-, 3 = sign+, 4 N/C, 5.

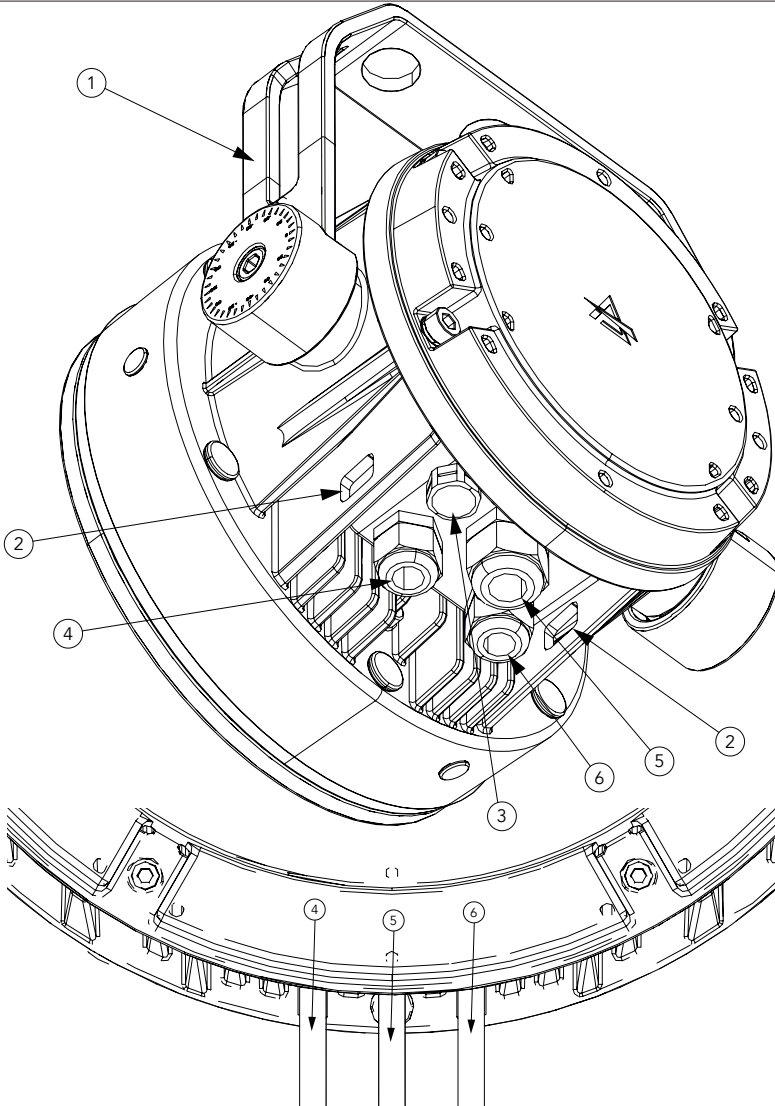

Fig. 03

5 - CONNECTION TO THE MAINS SUPPLY

WARNING: For protection from electric shock, the fixture must be earthed!

The product is equipped with auto-switching power supply that automatically adjusts to any 50-60Hz AC power source from 100-240 Volts (max absolute range : 90- 264V).

If you need to install a power plug on the power cable to allow connection to power outlets, install a grounding-type (earthed) plug, following the plug manufacturer's instructions. If you have any doubts about proper installation, consult a qualified electrician.

The max power consumption is 30W.

Core (EU)	Core (US)	Connection	Plug terminal marking
Brown	Black	Live	L
Blue	White	Neutral	N
Yellow+green	Green	Earth	

6 - START UP

CONNECT AND DISCONNECT POWER FROM THE PRODUCT

To apply and disconnect power to the product:

- Check that the product is installed and secured as indicated in the Safety Informations, and that personal safety will not be put at risk when the fixture lights up.
- Connect the power connector into the Mains input socket (100-240 VAC-50/60 Hz).
- The product is then ready for its operations and can be controlled through the available input signals on board.
- To disconnect power from the product, disconnect the Mains from the socket.

7 - DMX CONNECTION

CONNECTION OF THE CONTROL SIGNAL: DMX LINE

The product has connectors for DMX input and output.

The default pin-out on both connectors is as the following diagram:



Fig. 06

INSTRUCTIONS FOR A RELIABLE DMX CONNECTION

Use shielded twisted-pair cable designed for RS-485 devices: standard microphone cable cannot transmit control data reliably over long runs. 24 AWG cable is suitable for runs up to 300 meters (1000 ft). Heavier gauge cable and/or an amplifier is recommended for longer runs.

To split the data link into branches, use splitter-amplifiers in the connection line.

Do not overload the link. **Up to 32 devices may be connected on a serial link.**

NOTE: To connect the unit to your DMX network, it is necessary to use the adapters XLR 5 pin-IP67 signal connector, supplied with this product.

CONNECTION DAISY CHAIN OF THE DMX LINE

Connect the DMX data output from the DMX source to the product DMX input (male connector).

Run the data link from the product DMX output (female connector) connector to the DMX input of the next fixture.

Terminate the data link by connecting a 120 Ohm signal termination.

The termination is prepared by 120Ω 1/4 W resistor between pins 2 and 3 of the male DMX connector. Install a DMX termination plug on the last fixture on the link. If a splitter is used, terminate each branch of the link.

NOTE: when not using the DMX input or DMX output connectors, you must seal the cable ends with the supplied caps.

CONNECTION OF THE DMX LINE

DMX connection employs standard XLR connectors. Use shielded pair-twisted cables with 120Ω impedance and low capacity.

The following diagram shows the connection mode:

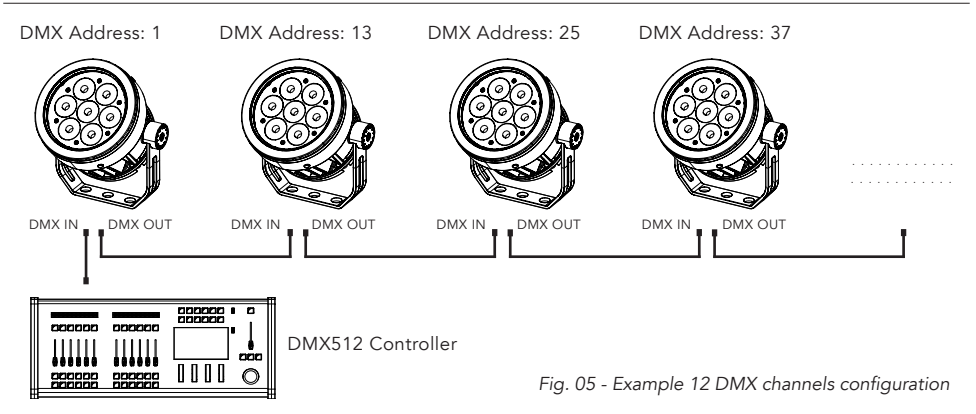

Fig. 05 - Example 12 DMX channels configuration

CONSTRUCTION OF THE DMX TERMINATION

The termination is prepared by soldering a 120Ω 1/4 W resistor between pins 2 and 3 of the male XLR connector, as shown in figure.

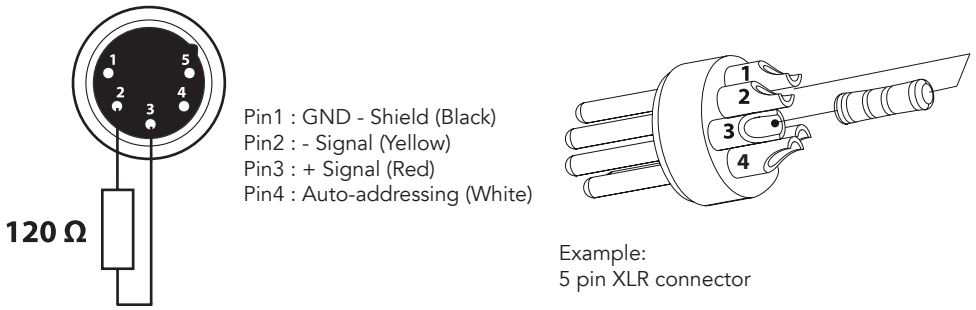

Fig. 06

8 - OPERATION VIA DATAMASTER

The unit uses a DATAMASTER for configuration purposes. The diagram below shows how to connect the DATAMASTER to this product. This connection will control multiple products at the same time. To set different Stand Alone mode on different product, you must connect the DATAMASTER to each product, individually.

However, by using the DATAMASTER, you may address each product in the daisy chain to a different DMX address by using the RDM function without the need connect to each individual product.

Important: The DATAMASTER must be used to configure this product.

MUSIC & LIGHTS suggests that you connect no more than 11 units in this mode and keep the total distance to less than 60 m (197 ft). Otherwise, you might need to use an RDM optically isolated signal amplifier.

RDM SETTING

To set the RDM functions with the DATAMASTER follow these steps:

- Turn on the DATAMASTER;
- Select the "RDM" function;
- Wait the discovering of all units;
- Select the desired unit and press ENTER button;
- Change the value of the desired function.

For the operating procedure, refer to the DATAMASTER user manual.

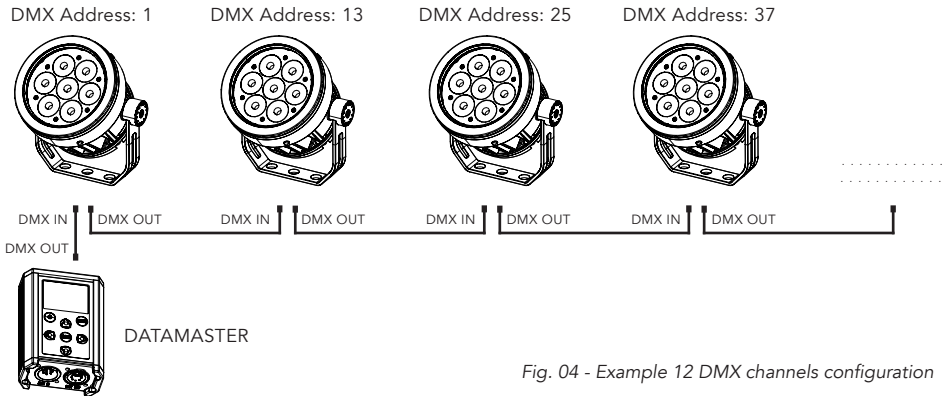

9 - RDM MENU STRUCTURE

The following chart describes the MENU tree of the product, the terms shown in **BOLD** indicates the default settings.

N°	MENU	LEVEL 1	LEVEL 2	LEVEL 3	DESCRIPTION
1	DMX ADDRESS	001 - 512			Set address used for Fixture.
2	DMX MODE	5CH			Set DMX chart for Main Fixture.
		6CH			
		9CH			
		12CH			
3	DIMMER CURVE	LINEAR			Select Dimmer curve.
		S-CURVE			
		SQUARE LAW			
		INVERSE SQUARE LAW			
4	DIMMER SPEED	AUTO			Select Dimmer speed.
		FAST			
		MEDIUM			
		SLOW			
		OFF			
5	LED FREQUENCY	600Hz			Select LED PWM frequency.
		1200Hz			
		2000Hz			
		4000Hz			
		6000Hz			
		25kHz			
6	DMX FAULT	HOLD			Define the behaviour of fixture in case of DMX signal lost.
		BLACKOUT			
		STAND ALONE			
7	ADVANCED	SPEKTRA	ON		CCT and colors are fully calibrated, working in the common color space definition set by Spektra. This means that output of multiple fixtures will match with no visible differences. Color Saturation is slightly reduced.
			PURE COLORS		CCT is calibrated, giving perfect white matching across multiple fixtures, but primary and secondary colors are calibrated to their native color space which allows maximum color saturation. The closer you move towards white, the more closely multiple fixtures will match each other's output. The further you move away from white and the closer you move towards saturated color, the less closely multiple fixtures will match each other's output.
			OFF		CCT doesn't guarantee High CRI Values and color output of one fixture may or may not closely match that of other fixtures.
		LED MODE	HIGH BRIGHTNESS		Delivering the full output on every primary color.
			HIGH QUALITY		Calibrated white output at 6000K, when all primary colors are set to full.

N°	MENU	LEVEL 1	LEVEL 2	LEVEL 3	DESCRIPTION
7	ADVANCED	WHITE POINT	FULL ON		
			3200K		
			4000K		
			5600K		
			6000K		
		8000K			
8	INFORMATIONS	DEVICE TIME	FIXTURE HOURS	TOTAL	To check the total working hours of the unit.
				PARTIAL	
			CURRENT HOURS	TOTAL	To check the current working hours of the unit.
				PARTIAL	
			SOURCE HOURS	TOTAL	To see the total operating hours of the LED source.
				PARTIAL	
		POWER ON CYCLE	TOTAL	To see the power cycles of the machine.	
			PARTIAL		
		MAINTENANCE TIME	ELAPSED TIME	To choose and reset unit maintenance warning hours.	
			ALERT PERIOD		
		POWER CONSUMPTION		Show actual power consumption.	
		TEMPERATURE	NEAR SOURCE TEMP, DRIVER PCB TEMP, LED PCB TEMP,...	To see the unit temperature.	
SOFTWARE VERSION		View informations about software version.			
DEVICE INFO		View informations about device.			
DEVICE LABEL		Show RDM Device label.			
RDM UID		View ID for the RDM control.			
9	STAND ALONE	MASTER/SLAVE	MASTER DMX		Allow you to link and operating in synk multiple units without a DMX console. Choose a unit to perform as the Master. This unit must be the first unit in line; Set the successive units to be slave.
			MASTER NO DMX		
			SLAVE		
		EFFECTS	EFFECT 1	SPEED:1-100	Effects modes allows creation and editing of 5 effects maximum. Each effect contains up to 20 colors, a Main Dimmer and a Main Strobe.
			...		
			EFFECT 5		
		STATIC COLORS	RED	DIMMER:0-255	Select of the following predefined color combination and its Dimmer value. After enabled this mode, the unit will be automatically assigned as Master.
			...		
			FULL		
		COLOR MACRO	SEE COLOR MACRO PAGE		
		WHITE PRESETS	2700K	DIMMER:0-255	
			3200K		
			...		
			10000K		
		MANUAL	RED	DIMMER:0-255	User generated color preset by assigning values to each primary color attribute. After enabled this mode, the unit will be automatically assigned as Master.
GREEN	DIMMER:0-255				
BLUE	DIMMER:0-255				
WARM WHITE	DIMMER:0-255				
10	FACTORY DEFAULT	-			

10 - RDM FUNCTIONS

The product can communicate using RDM (Remote Device Management) protocol over a DMX512 Networks.

RDM is a bi-directional communications protocol for use in DMX512 control systems, it is the open standard for DMX512 device configuration and status monitoring.

The RDM protocol allows data packets to be inserted into a DMX512 data stream without affecting existing non-RDM equipment. It allows a console or dedicated RDM controller to send commands to and receive messages from specific fixtures.

The PIDs in the following tables are supported in the product.

RDM is also available on Wireless and Tiny's Downstead must be enabled in its custom PIDs to work.

Category	Parameter	Value	GET	SET
Product Information	SUPPORTED_PARAMETERS	0x0050	x	
	PARAMETER_DESCRIPTION	0x0051	x	
	PRODUCT_DETAIL_ID_LIST	0x0070	x	
	DEVICE_MODEL_DESCRIPTION	0x0080	x	
	MANUFACTURER_LABEL	0x0081	x	
	DEVICE_LABEL	0x0082	x	x
	FACTORY_DEFAULTS	0x0090	x	x
DMX512 Setup	DMX_PERSONALITY	0x00E0	x	x
	DMX_PERSONALITY_DESCRIPTION	0x00E1	x	
	DMX_START_ADDRESS	0x00F0	x	x
	SLOT_INFO	0x0120	x	
	SLOT_DESCRIPTION	0x0121	x	
	DEFAULT_SLOT_VALUE	0x0122	x	
Sensors	SENSOR_DEFINITION	0x0200	x	
	SENSOR_VALUE	0x0201	x	x
	CURVE	0x0343	x	x
	CURVE_DESCRIPTION	0x0344	x	x
	OUTPUT_RESPONSE_TIME	0x0345	x	x
	OUTPUT_RESPONSE_TIME_DESCRIPTION	0x0346	x	
	MODULATION_FREQUENCY	0x0347	x	x
	MODULATION_FREQUENCY_DESCRIPTION	0x0348	x	
Power/Lamp Settings	DEVICE_HOURS	0x0400	x	x
	LAMP_HOURS	0x0401	x	x
	LAMP_STRIKES	0x0402	x	x
	LAMP_STATE	0x0403	x	x
	LAMP_MODE	0x0404	x	x
	DEVICE_POWER_CYCLES	0x0405	x	x

Manufacturer Specific PIDs

Parameter	PID	GET	SET	Value	Description
DMX FAULT	0x82DD	x	x	0-2	0: Hold 1: Blackout 2: Stand Alone
MASTER/SLAVE	0x8211	x	x	0-2	0: Master DMX 1: Master NO DMX 2: Slave
STAND ALONE MODE	0x82EC	x	x	0-4	0: S.A. EFFECTS 1: S.A. FIXED COLOR 2: S.A. WHITE PRESET 3: S.A. COLOR MACROS 4: S.A. MANUAL COLORS
EFFECTS	0x8209	x	x	1-5	DEFAULT: 1
EFFECTS SPEED	0x8210	x	x	1-100	DEFAULT: 100
SPEKTRA CALIBRATION	0x822F	x	x	0-2	0: ON 1: Pure Colors 2: OFF
FIXED COLOR	0x82BE	x	x	0-14	0: R 1: G 2: B 3: W 4: RG 5: RB 6: RW 7: GB 8: GW 9: BW 10:RGB 11:RGW 12:RBW 13:GBW 14:RGBW
WHITE PRESET	0x82BF	x	x	0-16	0: 2700K 1: 2800K 2: 3200K 3: 3500K 4: 4000K ... 16:10000K
MANUAL RED	0x82C0	x	x	0-255	DEFAULT: 255
MANUAL GREEN	0x82C1	x	x	0-255	DEFAULT: 255
MANUAL BLUE	0x82C2	x	x	0-255	DEFAULT: 255
MANUAL WHITE	0x82C3	x	x	0-255	DEFAULT: 255
COLOR MACROS	0x82ED	x	x	1-67	DEFAULT: 1
LED MODE	0x8330	x	x	0-1	0: High Brightness 1: High Quality
WHITE POINT	0x8331	x	x	0-5	0: FULL ON 1: 3200K 2: 4000K 3: 5600K 4: 6000K 5: 8000K
CURRENT HOURS	0x82C5	x		0-1	
POWER CONSUMPTION(AC 220V)	0x82EF	x		0-1	
MAINTENANCE TIME:ALERT PERIOD	0x82DF	x	x	10-300	DEFAULT: 300
MAINTENANCE TIME:ELAPSED TIME	0x82E0	x	x	0-1	DEFAULT: 0
ERROR MESSAGES	0x82EA	x		0-1	0: No Error
CLEAN ALL DATA	0x82C8	x	x	0-1	0: No 1: Yes

11 - DMX CHARTS

RDM Model ID: 0xD141

RDM Personality ID List

ID	DMX Mode	Footprint
1	5CH	5CH
2	6CH	6CH
3	9CH	9CH
4	12CH	12CH
5	13CH	13CH

PARAMETER	MODE				
	5CH	6CH	9CH	12CH	13CH
DIMMER		1	1	1	1
DIMMER FINE			2	2	2
CCT					3
CCT FINE					4
GMP					5
CROSSFADE					6
RED	1	2	3	3	7
GREEN	2	3	4	4	8
BLUE	3	4	5	5	9
WARM WHITE	4	5	6	6	10
STROBE			7	7	11
COLOR MACRO				8	
EFFECTS				9	
EFFECTS SPEED				10	
CONTROL			8	11	12
RESERVED	5	6	9	12	13

Dimmer

Function	8 bit value		16 bit value		Note
	From	To	From	To	
DIMMER	0	255	0	65535	Default @ 0

CCT

Function		8 bit value		16 bit value		Note
CCT From	CCT To	From	To	From	To	
2800	2900	0	4	0	910	Default @ 0
2900	3000	4	7	910	1820	
3000	3100	7	11	1820	2731	
3100	3200	11	14	2731	3641	
3200	3300	14	18	3641	4551	
3300	3400	18	21	4551	5461	
3400	3500	21	25	5461	6371	
3500	3600	25	28	6371	7282	
3600	3700	28	32	7282	8192	
3700	3800	32	35	8192	9102	
3800	3900	35	39	9102	10012	
3900	4000	39	43	10012	10923	
4000	4100	43	46	10923	11833	
4100	4200	46	50	11833	12743	
4200	4300	50	53	12743	13653	
4300	4400	53	57	13653	14563	
4400	4500	57	60	14563	15474	
4500	4600	60	64	15474	16384	
4600	4700	64	67	16384	17294	
4700	4800	67	71	17294	18204	
4800	4900	71	74	18204	19114	
4900	5000	74	78	19114	20025	
5000	5100	78	81	20025	20935	
5100	5200	81	85	20935	21845	
5200	5300	85	89	21845	22755	
5300	5400	89	92	22755	23665	
5400	5500	92	96	23665	24576	
5500	5600	96	99	24576	25486	
5600	5700	99	103	25486	26396	
5700	5800	103	106	26396	27306	
5800	5900	106	110	27306	28216	
5900	6000	110	113	28216	29127	
6000	6100	113	117	29127	30037	
6100	6200	117	120	30037	30947	
6200	6300	120	124	30947	31857	
6300	6400	124	128	31857	32768	
6400	6500	128	131	32768	33678	
6500	6600	131	135	33678	34588	
6600	6700	135	138	34588	35498	
6700	6800	138	142	35498	36408	
6800	6900	142	145	36408	37319	
6900	7000	145	149	37319	38229	
7000	7100	149	152	38229	39139	
7100	7200	152	156	39139	40049	
7200	7300	156	159	40049	40959	
7300	7400	159	163	40959	41870	

7400	7500	163	166	41870	42780	Default @ 0
7500	7600	166	170	42780	43690	
7600	7700	170	174	43690	44600	
7700	7800	174	177	44600	45510	
7800	7900	177	181	45510	46421	
7900	8000	181	184	46421	47331	
8000	8100	184	188	47331	48241	
8100	8200	188	191	48241	49151	
8200	8300	191	195	49151	50061	
8300	8400	195	198	50061	50972	
8400	8500	198	202	50972	51882	
8500	8600	202	205	51882	52792	
8600	8700	205	209	52792	53702	
8700	8800	209	213	53702	54613	
8800	8900	213	216	54613	55523	
8900	9000	216	220	55523	56433	
9000	9100	220	223	56433	57343	
9100	9200	223	227	57343	58253	
9200	9300	227	230	58253	59164	
9300	9400	230	234	59164	60074	
9400	9500	234	237	60074	60984	
9500	9600	237	241	60984	61894	
9600	9700	241	244	61894	62804	
9700	9800	244	248	62804	63715	
9800	9900	248	251	63715	64625	
9900	10000	251	255	64625	65535	

GMP

Function	8 bit value		16 bit value		Note
	From	To	From	To	
-25% TO 0	0	127	-	-	"Default @ 128 Linear tint correction from -0.25 to +0.25"
NEUTRAL	128	128	-	-	
0 TO 25%	129	255	-	-	

Crossfade

Function	8 bit value		16 bit value		Note
	From	To	From	To	
LINEARY FROM 0% TO 100%	0	255	-	-	Default @ 255

Red

Function	8 bit value		16 bit value		Note
	From	To	From	To	
DIMMER	0	255	-	-	Default @ 255

Green

Function	8 bit value		16 bit value		Note
	From	To	From	To	
DIMMER	0	255	-	-	Default @ 255

Blue

Function	8 bit value		16 bit value		Note
	From	To	From	To	
DIMMER	0	255	-	-	Default @ 255

Warm White

Function	8 bit value		16 bit value		Note
	From	To	From	To	
DIMMER	0	255	-	-	Default @ 255

Strobe

Function	8 bit value		16 bit value		Note
	From	To	From	To	
OPEN	0	1	-	-	Default @ 255
STROBE FROM SLOW TO FAST	2	62	-	-	
OPEN	63	64	-	-	
PULSE IN FROM SLOW TO FAST	65	125	-	-	
CLOSE	126	127	-	-	
PULSE OUT FROM SLOW TO FAST	128	188	-	-	
OPEN	189	190	-	-	
RANDOM FROM SLOW TO FAST	191	251	-	-	
OPEN	252	255	-	-	

Color Macro

Function	8 bit value		16 bit value		Note
	From	To	From	To	
NO FUNCTION	0	1	-	-	Default @ 0
RED	2	3	-	-	
GREEN	4	5	-	-	
BLUE	6	7	-	-	
CYAN	8	9	-	-	
MAGENTA	10	11	-	-	
YELLOW	12	13	-	-	
DIRTY WHITE	14	15	-	-	
ALICE BLUE	16	17	-	-	
CONGO BLUE	18	19	-	-	
DARK STEEL BLUE	20	21	-	-	
DEEP LAVENDER	22	23	-	-	
LILAC TING	24	25	-	-	
DAYLIGHT BLUE	26	27	-	-	
FLAME RED	28	29	-	-	
BASTARD AMBER	30	31	-	-	
DEEP ORANGE	32	33	-	-	
PALE GOLD	34	35	-	-	
APRICOT	36	37	-	-	
BRIGHT BLUE	38	39	-	-	
PRIMARY GREEN	40	41	-	-	
SPECIAL LAVENDER	42	43	-	-	
PALE LAVENDER	44	45	-	-	
DEEP GOLDEN AMBER	46	47	-	-	
MEDIUM BLUE	48	49	-	-	
BRIGHT PINK	50	51	-	-	
MAUVE	52	53	-	-	
DARK GREEN	54	55	-	-	
LEE GREEN	56	57	-	-	
DARK BLUE	58	59	-	-	
LIGHT BLUE	60	61	-	-	
STEEL BLUE	62	63	-	-	
MEDIUM BLUE-GREEN	64	65	-	-	
PEACOCK BLUE	66	67	-	-	
MAGENTA	68	69	-	-	
DARK PINK	70	71	-	-	
MIDDLE ROSE	72	73	-	-	
LIGHT SALMON	74	75	-	-	
ENGLISH ROSE	76	77	-	-	
LIGHT ROSE	78	79	-	-	
ORANGE	80	81	-	-	
DEEP AMBER	82	83	-	-	
STRAW	84	85	-	-	
LIGHT AMBER	86	87	-	-	
SPRING YELLOW	88	89	-	-	
DARK YELLOW GREEN	90	91	-	-	
JUST BLUE	92	93	-	-	
SKY BLUE	94	95	-	-	
LAVENDER	96	97	-	-	
LIGHT LAVENDER	98	99	-	-	
PINK CARNATION	100	101	-	-	

MEDIUM PINK	102	103	-	-
LIGHT PINK	104	105	-	-
SUNSET RED	106	107	-	-
DARK AMBER	108	109	-	-
GOLD AMBER	110	111	-	-
MEDIUM AMBER	112	113	-	-
FIRE	114	115	-	-
SURPRISE PEACH	116	117	-	-
STRAW TINT	118	119	-	-
MEDIUM YELLOW	120	121	-	-
LEE MINUS GREEN	122	123	-	-
PALE GOLD	124	125	-	-
ORANGE	126	127	-	-
DEEP STRAW	128	129	-	-
ROSE PURPLE	130	131	-	-
DEEP PURPLE	132	133	-	-
SOFT GREEN	134	135	-	-
RESERVED FOR FUTURE USE	136	211	-	-
2800K	212	213	-	-
3000K	214	215	-	-
3200K	216	217	-	-
3400K	218	219	-	-
3600K	220	221	-	-
3800K	222	223	-	-
4000K	224	225	-	-
4200K	226	227	-	-
4400K	228	229	-	-
4600K	230	231	-	-
4800K	232	233	-	-
5000K	234	235	-	-
5200K	236	237	-	-
5400K	238	239	-	-
5600K	240	241	-	-
6000K	242	243	-	-
6500K	244	245	-	-
7000K	246	247	-	-
8000K	248	249	-	-
9000K	250	251	-	-
10000K	252	253	-	-
FULL ON	254	255	-	-

Default @ 0

Effects

Function	8 bit value		16 bit value		Note
	From	To	From	To	
NO FUNCTION	0	10	-	-	Default @ 0
FX 1	11	60	-	-	
FX 2	61	110	-	-	
FX 3	111	160	-	-	
FX 4	161	210	-	-	
FX 5 (FX 1 -4)	211	255	-	-	

Effects Speed

Function	8 bit value		16 bit value		Note
	From	To	From	To	
FROM SLOW TO FAST	0	255	-	-	Default @ 128

Control

Function	8 bit value		16 bit value		Note
	From	To	From	To	
No Functon	0	1	-	-	Default @ 0
DIMMER CURVE LINEAR	2	3	-	-	
DIMMER CURVE S-CURVE	4	5	-	-	
DIMMER CURVE SQUARE LAW	6	7	-	-	
DIMMER CURVE INVERSE SQUARE LAW	8	9	-	-	
DIMMER SPEED AUTO	10	11	-	-	
DIMMER SPEED FAST	12	13	-	-	
DIMMER SPEED MEDIUM	14	15	-	-	
DIMMER SPEED SLOW	16	17	-	-	
DIMMER SPEED OFF	18	19	-	-	
LED FREQUENCY 600HZ	20	21	-	-	
LED FREQUENCY 1200HZ	22	23	-	-	
LED FREQUENCY 2000HZ	24	25	-	-	
LED FREQUENCY 4000HZ	26	27	-	-	
LED FREQUENCY 6000HZ	28	29	-	-	
LED FREQUENCY 25KHZ	30	31	-	-	
DMX FAULT HOLD	32	33	-	-	
DMX FAULT BLACKOUT	34	35	-	-	
DMX FAULT STAND ALONE	36	37	-	-	
SPEKTRA CALIBRATION ON	38	39	-	-	
SPEKTRA CALIBRATION PURE COLORS	40	41	-	-	
SPEKTRA CALIBRATION OFF	42	43	-	-	
LED MODE HIGH BRIGHTNESS	44	45	-	-	
LED MODE HIGH QUALITY	46	47	-	-	
WHITE POINT FULL ON	48	49	-	-	
WHITE POINT 3200K	50	51	-	-	
WHITE POINT 4000K	52	53	-	-	
WHITE POINT 5600K	54	55	-	-	
WHITE POINT 6000K	56	57	-	-	
WHITE POINT 8000K	58	59	-	-	
STAND ALONE MASTER DMX	60	61	-	-	
STAND ALONE MASTER NO DMX	62	63	-	-	
STAND ALONE SLAVE	64	65	-	-	
STAND ALONE EFFECTS	66	67	-	-	
STAND ALONE STATIC COLORS	68	69	-	-	
STAND ALONE WHITE PRESETS	70	71	-	-	
STAND ALONE COLOR MACROS	72	73	-	-	
STAND ALONE MANUAL COLORS	74	75	-	-	
RESERVED	76	249	-	-	
RESET ALL CHANNEL CONTROLLED	250	251	-	-	
RESERVED	252	255	-	-	

12 - ACCESSORIES INSTALLATION

HALF SNOOT (CODE ARSHSNOOTGY - OPTIONAL)

1

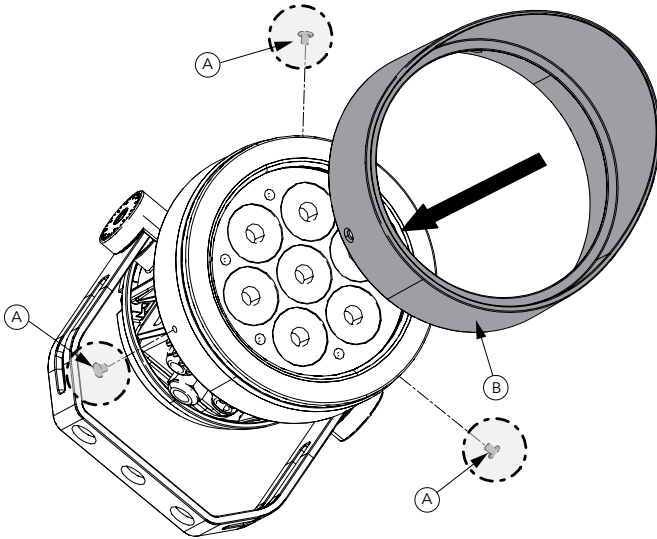

2

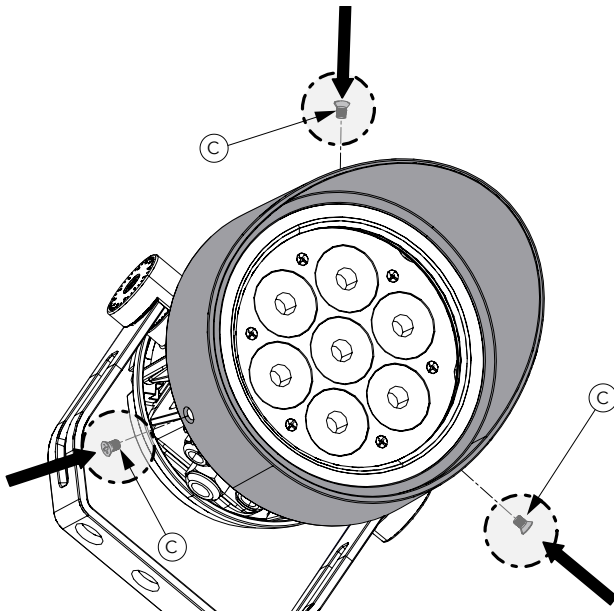

Place fixture on a stable surface.

1. Remove rubber caps (A). Insert the Half snoot (B).
2. Screw the supplied screws (C) to secure the accessory.

Fig. 08

HONEYCOMB LOUVRE (CODE ARSHLOUVREGY - OPTIONAL)

1

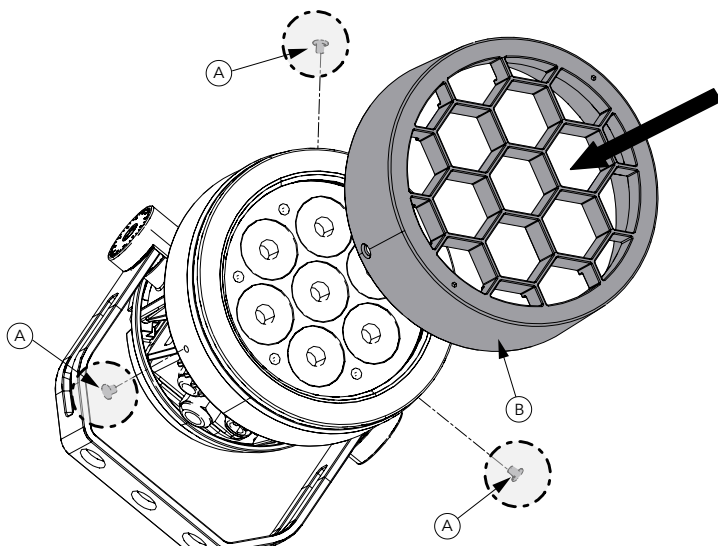

2

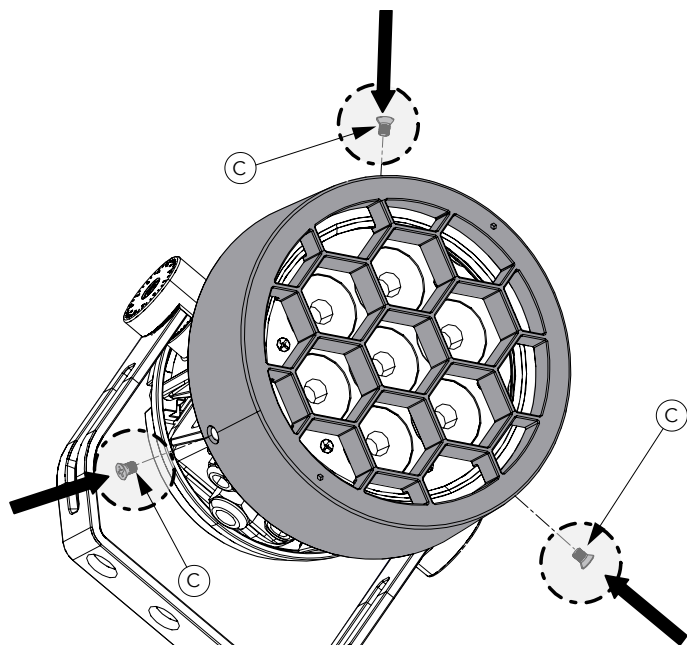

Place fixture on a stable surface.

1. Remove rubber caps (A). Insert the Honeycomb louvre (B).
2. Screw the supplied screws (C) to secure the accessory.

Fig. 09

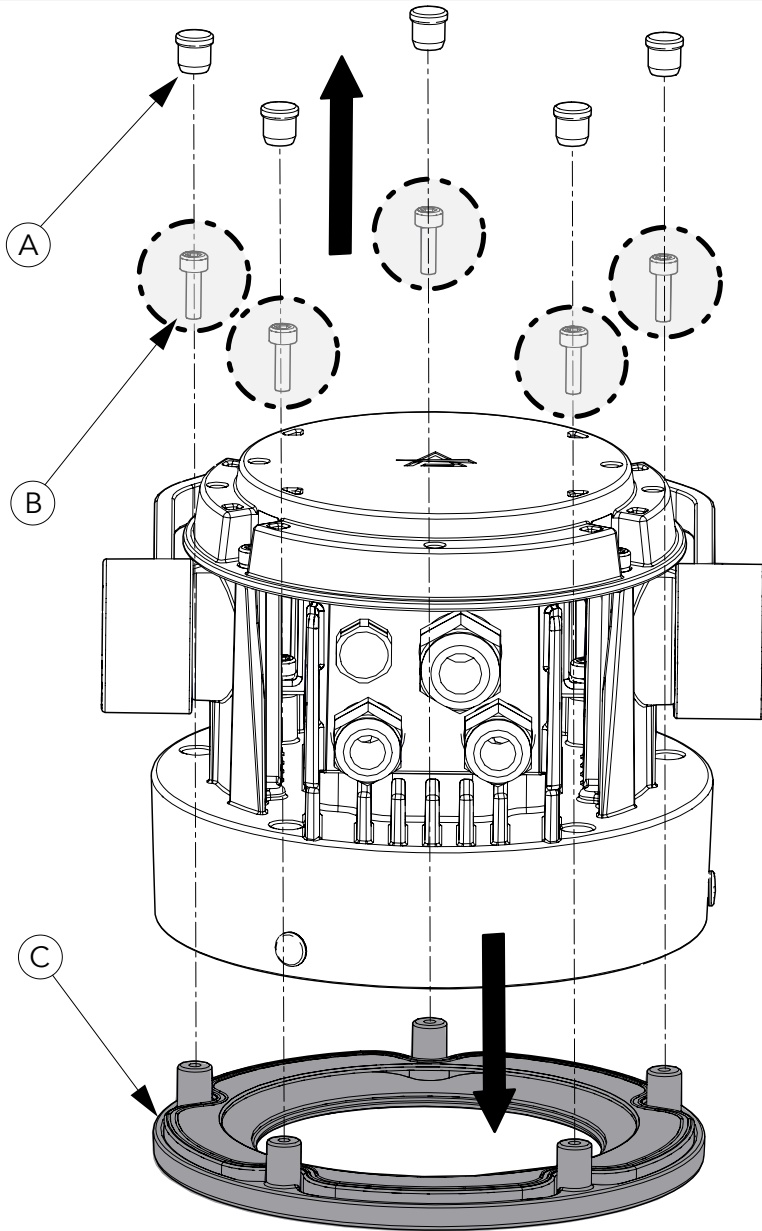

Place fixture on a stable surface.

- Remove the rubber caps (A), then unscrew the metal front ring screws (B).
- Remove the metal front ring (C).

NOTE: the installation images refers to ARCSPOTXS

Fig. 10

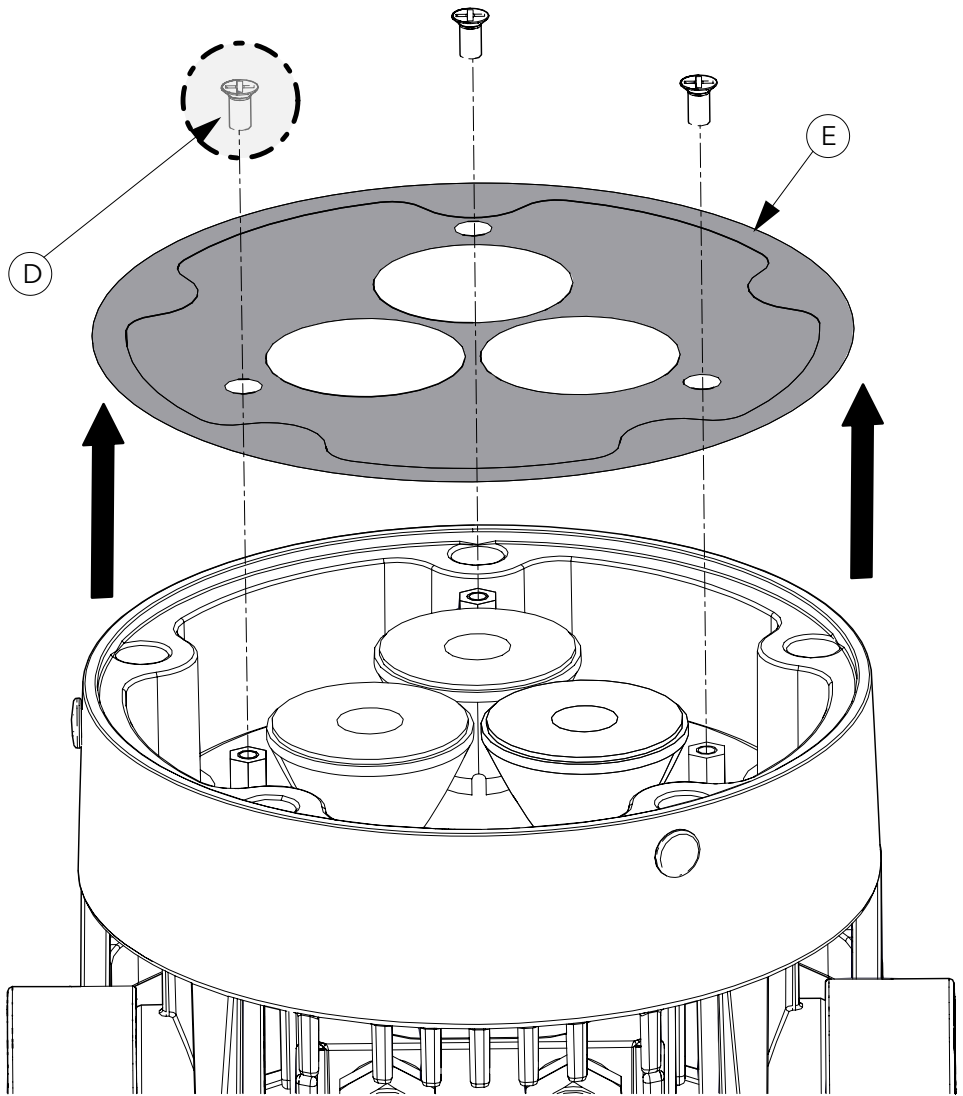

Turn the fixture with lenses upside and proceed as follows:

- Unscrew the lenses holder screws (D).
- Remove the lenses holder (E).

NOTE: be careful to match the spaces (F) in the same way as they are disassembled to close the product correctly.

Fig. 11

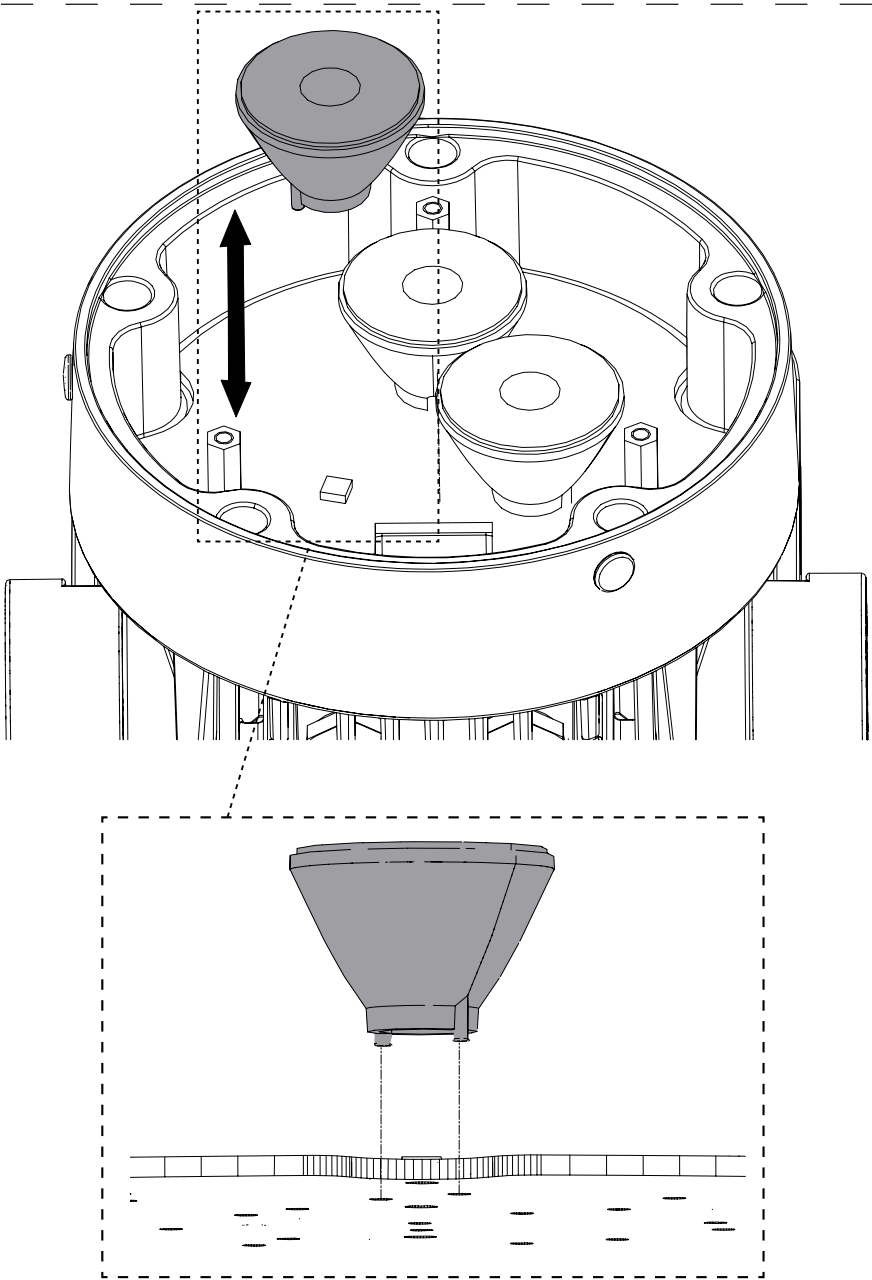

Gently replace each lens as shown in figure,

Fig. 12

13 - MAINTENANCE

MAINTENANCE AND CLEANING THE PRODUCT

WARNING: Disconnect from the mains before starting any maintenance work

It is recommended to clean the front at regular intervals, from impurities caused by dust, smoke, or other particles to ensure that the light is radiated at maximum brightness.

- For cleaning, disconnect the main plug from the socket. Use a soft, clean cloth moistened with a mild detergent. Then carefully wipe the part dry. For cleaning other housing parts use only a soft, clean cloth. Never use a liquid, it might penetrate the unit and cause damage to it.
- The user must clean the product periodically to maintain optimum performance and cooling.
- The user may also upload firmware (product software) to the fixture via the DMX signal input port using UPBOXPRO or UPBOX2 and instructions from PROLIGHTS.
- The frequency of such maintenance operations is to be performed according to various factors, such as the amount of the use and the condition of the installation environment (air humidity, presence of dust, salinity, etc.). It is recommended that the product is subject to annual service by a qualified technician for special maintenance involving at least the following procedures:
- General cleaning of internal parts.
- For all the parts subject to friction, using lubricants specifically supplied by PROLIGHTS.
- General visual check of the internal components, cabling, mechanical parts, etc.
- Electrical, photometric and functional checks; eventual repairs.
- Cleaning the lenses. Only use neutral soap and water to clean the lenses, then dry it carefully with a soft, non-abrasive cloth.

WARNING: the use of alcohol or any other detergent could damage the lenses.

- **Only for IP66 projectors:** It is recommended to verify IP grade using IPTESTBOX every time the bodies are removed for maintenance, this tool helps to double check the correct assembling of the covers with a check of the IP grade of the fixture.
- All other service operations on the product must be carried out by PROLIGHTS, its approved service agents or trained and qualified personnel.
- It is PROLIGHTS policy to apply the strictest possible calibration procedures and use the best quality materials available to ensure optimum performance and the longest possible component lifetimes. However, optical components are subject to wear and tear over the life of the product, resulting in gradual changes in colours over many thousands of hours of use. The extent of wear and tear depends heavily on operating conditions and environment, so it is impossible to specify precisely whether and to what extent performance will be affected. However, you may eventually need to replace optical components if their characteristics are affected by wear and tear after an extended period of use and if you require fixtures to perform within very precise optical and colour parameters.
- Do not apply filters, lenses or other materials on lenses or other optical components. Use only accessories approved by PROLIGHTS.

VISUAL CHECK OF PRODUCT HOUSING

- The parts of the product cover/housing should be checked for eventual damages and breaking start at least every two months. In addition, especially the parts of the front lens holder have to be checked mechanically (by means of movement by the part) if it is firmly fastened to the fixture. If hint of a crack is found on some plastic part, do not use the product until the damaged part will be replaced.
- Cracks or another damages of the cover/housing parts can be caused by the product transportation or manipulation and also ageing process may influence materials.
- This checking is necessary for both fixed installations and preparing product for renting. Any free moving parts inside of the product, cracked cover/housing or any part of front lens not sitting properly in place need to be immediately replaced.

14 - TEST OF IP66 RATING

It is recommended to verify IP grade using IPTESTBOX every time the bodies are removed for maintenance.

1

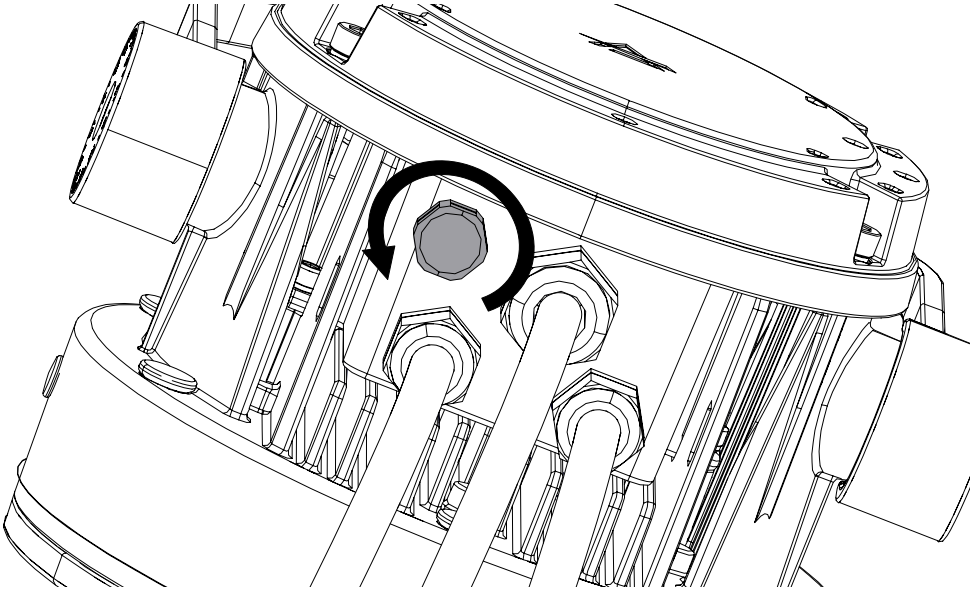

Remove the gore valve from the rear cover.

2

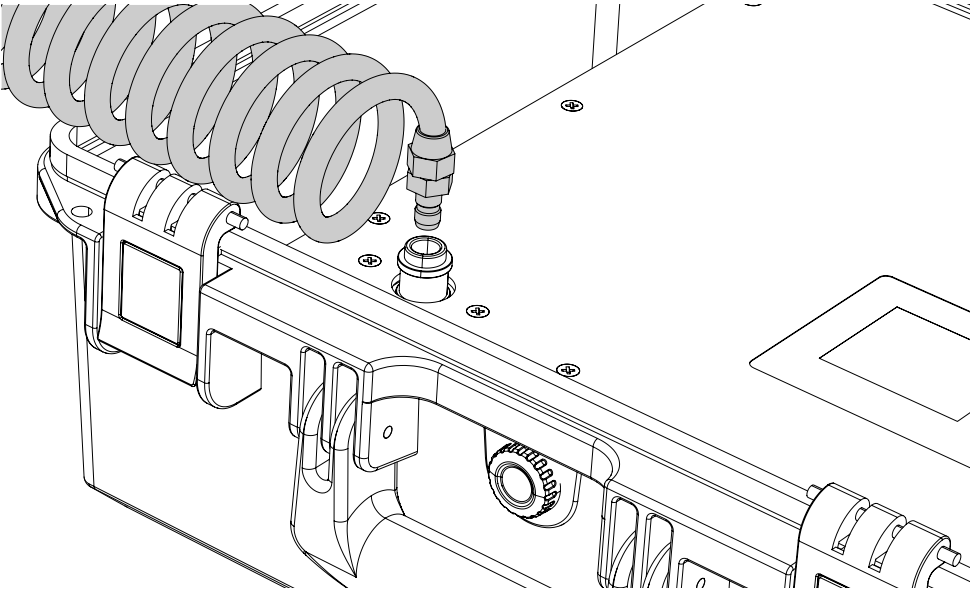

Connect the air hose to the IPTESTBOX by inserting the quick-connect fitting into the coupler.

3

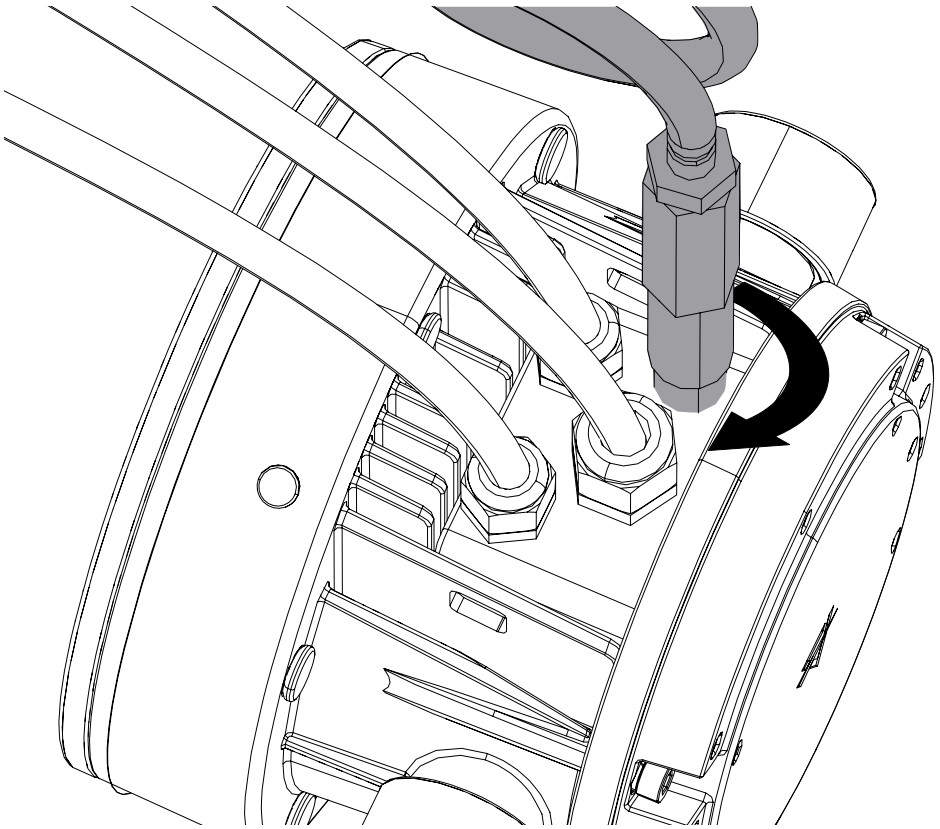

Insert the threaded end into the threaded valve hole socket.

For the operating procedure using the instrument, refer to the IPTESTBOX user manual.

Fig. 13



PROLIGHTS is a trademark of
MUSIC & LIGHTS S.r.l.
musiclights.it

Via A.Olivetti snc
04026 - Minturno (LT) ITALY
Tel: +39 0771 72190

prolights.it
support@prolights.it