



**LumiPix XB050**

**LumiPix XB100**

IP65 RGB+WW pixel-controlled linear  
LED fixture



---

# USER MANUAL

---

## Thank you for choosing PROLIGHTS

Please note that every PROLIGHTS product has been designed in Italy to meet quality and performance requirements for professionals and designed and manufactured for the use and application as shown in this document.

Any other use, if not expressly indicated, could compromise the good condition/operation of the product and/or be a source of danger.

This product is meant for professional use. Therefore, commercial use of this equipment is subject to the respectively applicable national accident prevention rules and regulations.

Features, specifications and appearance are subject to change without notice. Music & Lights S.r.l. and all affiliated companies disclaim liability for any injury, damage, direct or indirect loss, consequential or economic loss or any other loss occasioned by the use of, inability to use or reliance on the information contained in this document.

Product user manual can be downloaded from the website [www.prolights.it](http://www.prolights.it), or can be inquired to the official PROLIGHTS distributors of your territory ([https://www.prolights.it/sales\\_network.html](https://www.prolights.it/sales_network.html)).

Scanning the below **QR Code**, you will access the download area of the product page, where you can find a broad set of always updated technical documentation: specifications, user manual, technical drawings, photometrics, personalities, fixture firmware updates.



Visit the download area  
of the product page

LUMIPIXB050 LUMIPIXB100



The PROLIGHTS Logo, PROLIGHTS names and all other trademark in this document pertaining to PROLIGHTS services or PROLIGHTS product are trademarks OWNED or licensed by Music & Lights S.r.l., its affiliates, and subsidiaries. PROLIGHTS is a registered trademark by Music & Lights S.r.l. All right reserved. Music & Lights – Via A. Olivetti, snc - 04026 - Minturno (LT) ITALY.

# INDEX

<b>SAFETY INFORMATION</b>	<b>02</b>
<b>1 - PACKAGING</b>	<b>05</b>
PACKAGE CONTENT .....	05
OPTIONAL ACCESSORIES .....	05
<b>2 - TECHNICAL DRAWING</b>	<b>05</b>
<b>3 - INSTALLATION</b>	<b>06</b>
MOUNTING .....	06
<b>4 - CONNECTION TO THE MAINS SUPPLY</b>	<b>07</b>
<b>5 - START UP</b>	<b>07</b>
CONNECT AND DISCONNECT POWER FROM THE PRODUCT .....	07
<b>6 - PRODUCT OVERVIEW</b>	<b>08</b>
<b>7 - DMX CONNECTION</b>	<b>09</b>
CONNECTION OF THE CONTROL SIGNAL: DMX LINE .....	09
INSTRUCTIONS FOR A RELIABLE DMX CONNECTION .....	09
CONNECTION DAISY CHAIN .....	09
CONNECTION OF THE DMX LINE .....	09
CONSTRUCTION OF THE DMX TERMINATION .....	10
DMX ADDRESSING .....	10
ETHERNET CONNECTION .....	10
ETHERNET OPERATION .....	10
ETHERNET TO DMX OPERATIONS .....	11
OPERATION AS A WIRELESS TRANSMITTER .....	11
IN TO WDMX .....	11
OPERATION AS A WIRELESS RECEIVER .....	12
WDMX TO DMX (RX) .....	12
<b>8 - CONTROL PANEL</b>	<b>13</b>
DISPLAY AND BUTTONS LAYOUT .....	13
<b>9 - MENU STRUCTURE</b>	<b>14</b>
<b>10 - SHORTCUT</b>	<b>19</b>
<b>11 - RDM FUNCTIONS</b>	<b>20</b>
<b>12 - DMX CHARTS</b>	<b>24</b>
FIXTURE DMX CHARTS .....	26
PIXEL ENGINE DMX CHARTS (LUMIPIXXB050) .....	27
PIXEL ENGINE DMX CHARTS (LUMIPIXXB100) .....	28
CHANNEL DEFINITION .....	29
LEGACY MODEs .....	66
<b>13 - ACCESSORIES INSTALLATION</b>	<b>79</b>
BARNDOOR (CODE LPXB050BD / LPXB100BD - OPTIONAL) .....	79
60° EGGCRATE (CODE LPXB050EC60 / LPXB050EC100 - OPTIONAL) .....	80
LIGHT DIFFUSION FILTER (CODE LPXB050FILT20/40/60 / LPXB100FILT20/40/60 - OPTIONAL) .....	81
<b>14 - TEST OF IP65 RATING</b>	<b>82</b>
<b>15 - MAINTENANCE</b>	<b>83</b>
MAINTENANCE AND CLEANING THE PRODUCT .....	83
VISUAL CHECK OF PRODUCT HOUSING .....	83
TROUBLESHOOTING .....	84

# SAFETY INFORMATION



## WARNING!

- See <https://www.prolights.it/product/LUMIPIXXB050#download> for installation instructions.
- See <https://www.prolights.it/product/LUMIPIXXB100#download> for installation instructions.
- Please read carefully the instruction reported in this section before installing, powering, operating or servicing the product and observe the indications also for its future handling.



**This unit is not for household and residential use, only professional applications.**



## Connection to mains supply

- The Connection to the mains supply must be carried out by a qualified electrical installer.
- Use only AC supplies 100-240V 50-60 Hz, the fixture must be electrically connected to ground (earth).
- Select the cable cross section in according with the maximum current draw of the product and the possible number of products connected at the same power line.
- The AC mains power distribution circuit must be equipped with magnetic+residual current circuit breaker protection.
- Do not connect it to a dimmer system; doing so may damage the product.



## Protection and Warning against electrical shock

- Do not remove any cover from the product, always disconnect the product from AC power before servicing.
- Ensure that the fixture is electrically connected to ground (earth). And use only a source of AC power that complies with local building and electrical codes and has both overload and ground-fault (earth-fault) protection.
- Before using the fixture, check that all power distribution equipment and cables are in perfect condition and rated for the current requirements of all connected devices.
- Isolate the fixture from power immediately if the power plug or any seal, cover, cable, or other components are damaged, defective, deformed or showing signs of overheating.
- Do not reapply power until repairs have been completed.
- Refer any service operation not described in this manual to PROLIGHTS Service team or an authorized PROLIGHTS service center.



## Installation

- Make sure that all visible parts of the product are in good visible condition before its use or installation.
- Make sure the point of anchorage is stable before positioning the projector.
- When suspending the fixture above ground level, secure it against failure of primary attachments by attaching a safety cable that is approved as a safety attachment for the weight of the fixture to the attachment point on the main frame of the product. In case the safety cable, enter in action, it needs to be replaced with a new one.
- Install the product only in well ventilated places.
- For non temporary installations, ensure that the fixture is securely fastened to a load-bearing surface with suitable corrosionresistant hardware.
- For a temporary installation with clamps, ensure that the quarter-turn fastener and/or screws are turned fully, and secured with a suitable safety cable.



## Minimum distance of illuminated objects

- The projector needs to be positioned so that the objects hit by the beam of light are at least 0,5 meters (1,64 ft) from the lens of the projector.

**T<sub>a</sub> 45°C**

#### **Max operating ambient temperature (T<sub>a</sub>)**

- Do not operate the fixture if the ambient temperature (T<sub>a</sub>) exceeds 45 °C (113 °F).

**T<sub>a</sub> -20°C**

#### **Minimum operating ambient temperature (T<sub>a</sub>)**

- Do not operate the fixture if the ambient temperature (T<sub>a</sub>) is below -20 °C (-4 °F).



#### **Protection from burns and fire**

- The exterior of the fixture becomes hot during use. Avoid contact by persons and materials.
- Ensure that there is free and unobstructed airflow around the fixture.
- Keep flammable materials well away from the fixture.
- Do not expose the front glass to sunlight or any other strong light source from any angle. Lenses can focus the sun's rays inside the fixture, creating a potential fire hazard.
- Do not attempt to bypass thermostatic switches or fuses.

**IP65**

#### **Outdoor (temporary) use**

- This product is rated with an IP (Ingress protection) for temporary outdoor use when used and serviced according to the instruction contained in this document.
- Never use the fixture in places subject to vibrations or bumps.
- Make certain that no inflammable liquids, water or metal objects enter the fixture.
- Excessive dust, smoke fluid, and particle build up degrades performance, causes overheating and will damage the fixture.
- Damages caused by inadequate cleaning or maintenance are not covered by the product warranty.

**T<sub>c</sub> 66°C**

#### **Temperature of the external surface**

- The surface of the fixture can reach up to 66 °C (150 °F) during operation. Avoid contact with people and materials.



#### **Maintenance**

- Warning! Disconnect the fixture from AC mains power and allow to cool for at least 10 minutes before handling.
- Only technicians who are authorized by PROLIGHTS or Authorised service partners are permitted to open the fixture.
- Users may carry out external cleaning, following the warnings and instructions provided, but any service operation not described in this manual must be referred to a qualified service technician.
- Important! Excessive dust, smoke fluid, and particle build up degrades performance, causes overheating and will damage the fixture. Damages caused by inadequate cleaning or maintenance is not covered by the product warranty.



#### **Photobiological safety**

- This device emits potentially dangerous optical radiation and is identified in the category of Risk Group 2 according to EN 62471.



#### **Do not stare at the operating light source**

- Do not look directly at the LED source during operation. It can be harmful to the eyes and skin.
- During Installation, operation and maintenance, be prepared for the fixture to light and move suddenly when connected to power.
- The LUMIPIX050 should be positioned so that prolonged staring into the luminaire at a distance closer than 10,50 m (34,45 ft) is not expected.
- The LUMIPIX100 should be positioned so that prolonged staring into the luminaire at a distance closer than 14,12 m (46,32 ft) is not expected.

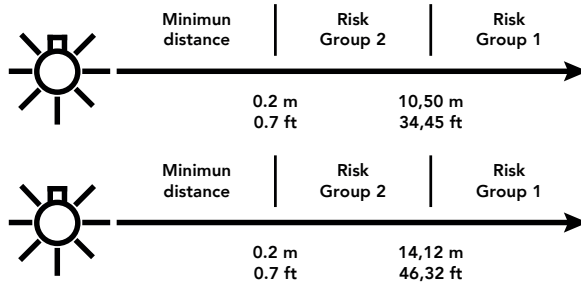

#### Disposal

- This product is supplied in compliance with European Directive 2012/19/EU – Waste Electrical and Electronic Equipment. (WEEE). To preserve the environment please dispose/ recycle this product at the end of its life according to the local regulation.



#### The products to which this manual refers comply with:

- 2014/35/EU - Safety of electrical equipment supplied at low voltage (LVD);
- 2014/30/EU - Electromagnetic Compatibility (EMC);
- 2011/65/EU - Restriction of the use of certain hazardous substances (RoHS);
- 2014/53/EU - Radio Equipment Directive (RED).



#### The products to which this manual refers comply with:

- UL 1573 + CSA C22.2 No. 166 - Stage and Studio Luminaires and Connector Strips.
- UL 1012 + CSA C22.2 No. 107.1 - Standard for power units other than class 2.



#### FCC Compliance:

- This device complies with Part 15 of the FCC Rules. Operation is subject to the following two conditions:
1. This device may not cause harmful interference, and
  2. This device must accept any interference received, including interference that may cause undesired operation.



#### Other approvals

# 1 - PACKAGING

## PACKAGE CONTENT

- 1x LUMIPIXXB050 / LUMIPIXXB100.
- 1x 1,5 meters power cable (BARE END - SEETRONIC IP65 power connector).
- 2x side floor brackets.
- User Manual.
- 1 x OS27: quick-Lock omega bracket, M10 hole.

## OPTIONAL ACCESSORIES

- FCLLUMIPIXXB: Flight case for 4 pcs LUMIPIXXB100 or 8 pcs LUMIPIXXB050.
- LPXB050BD: Barndoor to adjust the light beam for LUMIPIXXB050.
- LPXB050EC60: 60° egg crate for LUMIPIXXB050.
- LPXB050FILT20: light diffusion filter for LUMIPIXXB050, 20°.
- LPXB050FILT40: light diffusion filter for LUMIPIXXB050, 40°.
- LPXB050FILT60: light diffusion filter for LUMIPIXXB050, 60°.
- LPXB100BD: barndoor to adjust the light beam for LUMIPIXXB100.
- LPXB100EC60: 60° egg crate for LUMIPIXXB100.
- LPXB100FILT20: light diffusion filter for LUMIPIXXB100, 20°.
- LUMIPIXXB100: light diffusion filter for LUMIPIXXB100, 40°.
- LPXB100FILT60: light diffusion filter for LUMIPIXXB100, 60°.
- C6002A/B: slim aluminum clamp, 200kg loading, 48-51mm tubes, M10 bolt, silver/black.
- OS27: quick-Lock omega bracket, M10 hole.
- WSBBR512G5: blackBox R-512 G5 receiver 512Ch, 2.45GHz & 5.8GHz, DMX/RDM optional.
- WSBBF1G6: blackBox F-1 G6 transrec, 512ch, 2.45GHz, DMX&RDM,Bluetooth,G3,G4,G4S, G5, CRMX.
- WSBBF1G5: blackBox F-1 G5 transmitter, 2,45GHz & 5.2/5,8 GHz, DMX/RDM, 512Ch.
- TOUR53415L03: dmx cable HC5340. CANC5MXX XLR 5p->CANC5FFX XLR (f) 5p, L.3m.
- 958225L03: 3x2.5mm TH07 Cable, 16A 3p PwCon MXW, 16A 3p PwCon FXW, L. 3m.
- 9513FXWL03: ass. 3x2.5mm TH07 cable, 16A 3p 230V CEE plug, MENAC3FXW socket, L.3m.
- 9533FXWL03: ass. 3x2.5mm TH07 cable, SHUKO plug, MENAC3FXW socket, L.3m.
- RSR0630A/B: steel security cable for hanging bodies, inox steel shackle, L=60 cm, silver/black.
- WSBBR512G6: blackBox R-512 G6 receiver 512Ch, 2.45GHz,DMX&RDM,Bluetooth,G3,G4,G4S,G5,CRMX.
- UPBOX1UP5: firmware uploader kit, USB IN, 5pin XLR DMX OUT, USB OUT.

# 2 - TECHNICAL DRAWING

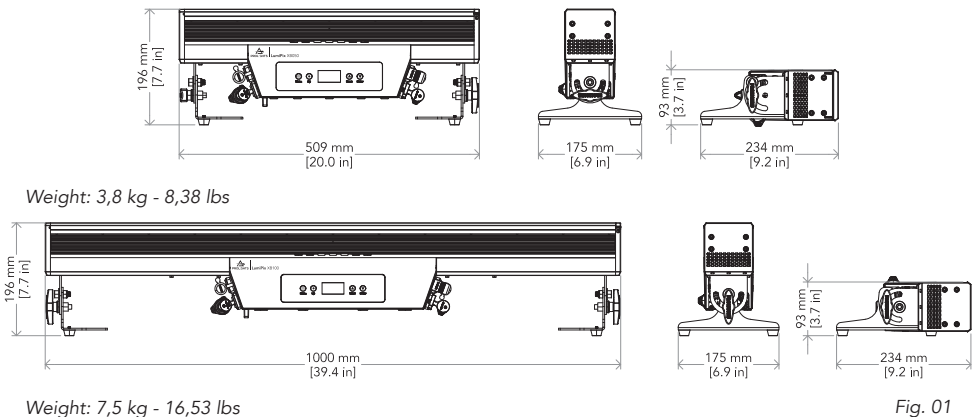

# 3 - INSTALLATION

## MOUNTING

Check that the supporting structure can safely bear the weight of all installed fixtures, clamps, cables, auxiliary equipment, etc. and complies with locally applicable regulations.

When suspending the fixture above ground level, secure it against failure of primary attachments by attaching a safety wire that is approved as a safety attachment for the weight of the fixture to an anchor point on the product main frame.

Do not use removable parts or weak anchors for secondary attachment.

Warning! When clamping the fixture to a truss or other structure at any angle, use clamps of half-coupler type. Do not use any type of clamp that does not completely encircle the structure when fastened.

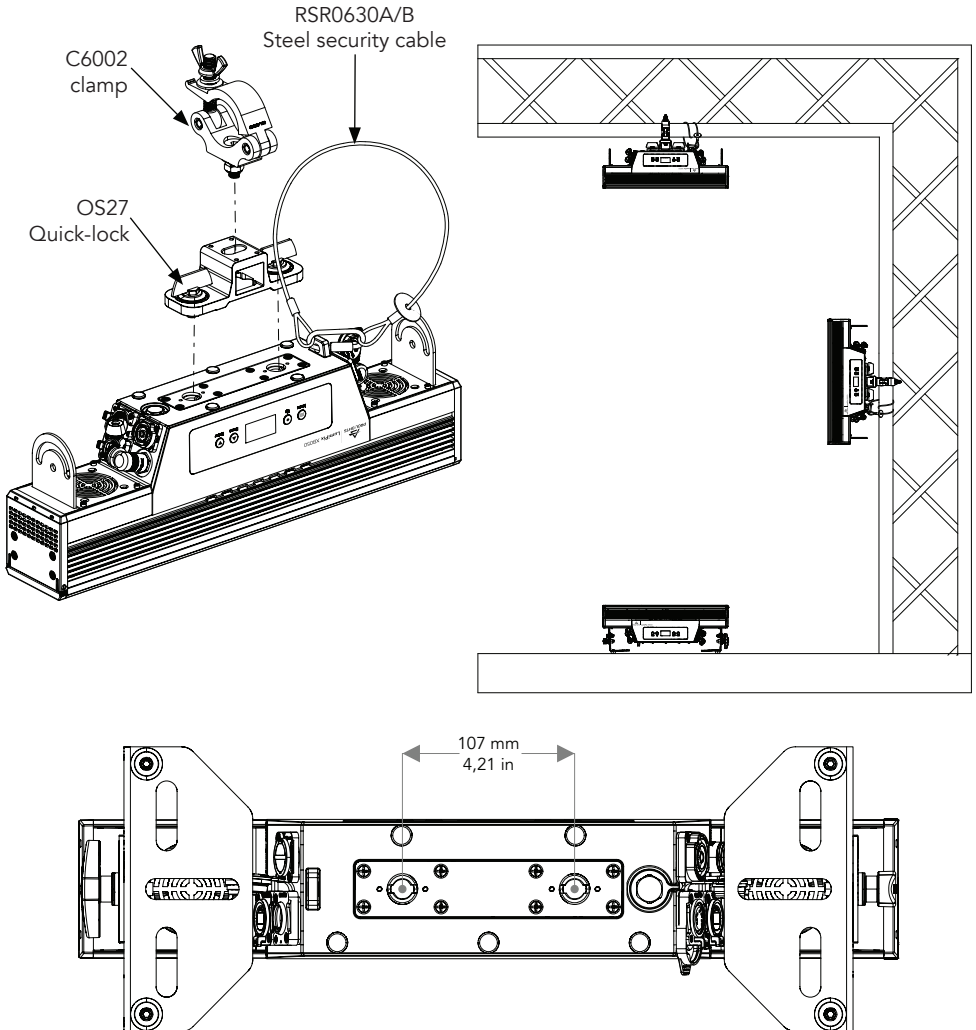

Fig. 02



## 4 - CONNECTION TO THE MAINS SUPPLY

**WARNING:** For protection from electric shock, the fixture must be earthed!

The product is equipped with auto-switching power supply that automatically adjusts to any 50-60Hz AC power source from 100-240 Volts.

If you need to install a power plug on the power cable to allow connection to power outlets, install a grounding-type (earthed) plug, following the plug manufacturer's instructions. If you have any doubts about proper installation, consult a qualified electrician.

The max power consumption is 150W (LUMIPIXB050) / 260W (LUMIPIXB100).

Core (EU)	Core (US)	Connection	Plug terminal marking
Brown	Black	Live	L
Blue	White	Neutral	N
Yellow+green	Green	Earth	

## 5 - START UP

### CONNECT AND DISCONNECT POWER FROM THE PRODUCT

To apply and disconnect power to the product:

- Check that the product is installed and secured as indicated in the Safety Informations, and that personal safety will not be put at risk when the fixture lights up.
- Connect the power connector into the Mains input socket (100-240 VAC-50/60 Hz).
- The product is then ready for its operations and can be controlled through the available input signals on board.
- To disconnect power from the product, disconnect the Mains from the socket.

## 6 - PRODUCT OVERVIEW

1. USER INTERFACE with display and buttons for access to the control panel functions.
2. Holes to attach Quick-lock.
3. SAFETY EYE to attach safety cable.
4. GORE VALVE.
5. SIDE FLOOR BRACKETS.
6. DMX IN (5-p XLR): 1 = GND, 2 = sign-, 3 = sign+, 4 N/C, 5 N/C.
7. ETHERCON CONNECTORS IN / OUT signal.
8. POWER IN: for connection to the Mains 100-240V~/50-60Hz.
9. ANTENNA.
10. POWER OUT: power output for connection of multiple units in series.
11. DMX OUT (5-p XLR): 1 = GND, 2 = sign-, 3 = sign+, 4 N/C, 5 N/C.

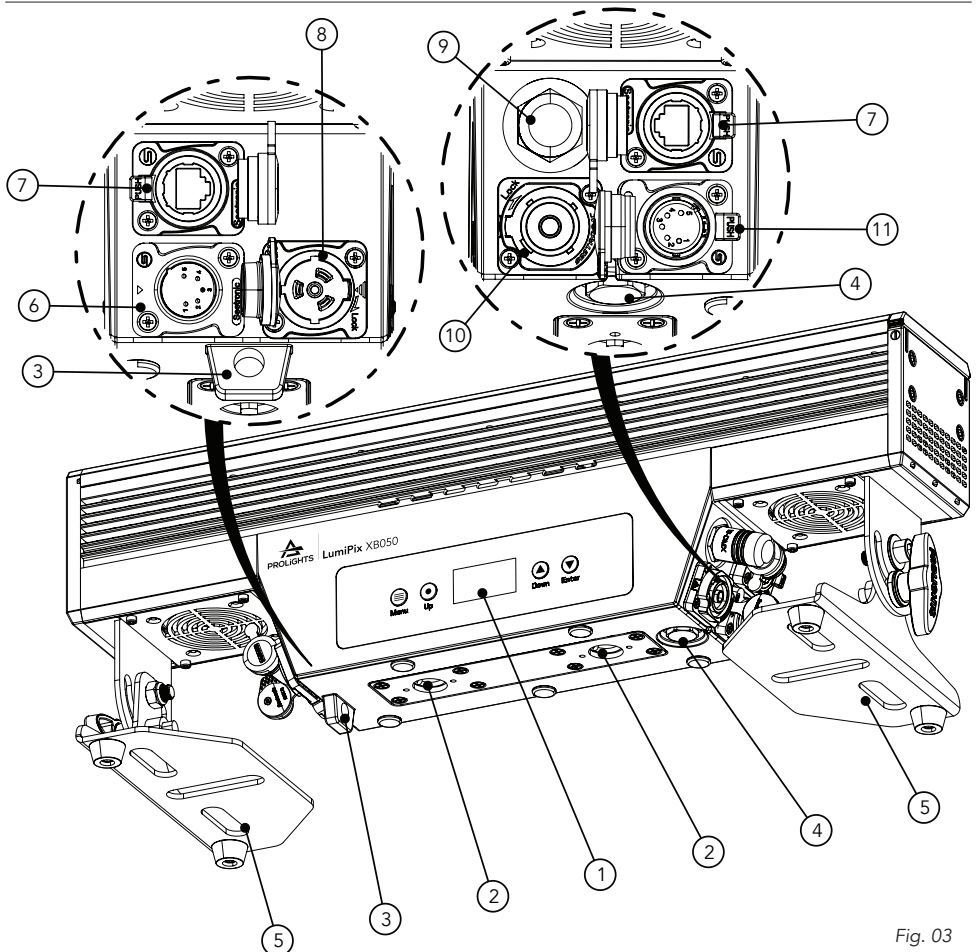

Fig. 03

# 7 - DMX CONNECTION

## CONNECTION OF THE CONTROL SIGNAL: DMX LINE

The product has XLR sockets for DMX input and output.

The default pin-out on both socket is as the following diagram:

### DMX - INPUT XLR plug



- Pin1 : GND - Shield
- Pin2 : - Signal
- Pin3 : + Signal
- Pin4 : N/C
- Pin5 : N/C

### DMX - OUTPUT XLR socket

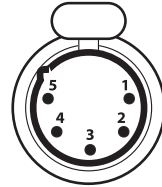

Fig. 04

## INSTRUCTIONS FOR A RELIABLE DMX CONNECTION

Use shielded twisted-pair cable designed for RS-485 devices: standard microphone cable cannot transmit control data reliably over long runs. 24 AWG cable is suitable for runs up to 300 meters (1000 ft). Heavier gauge cable and/or an amplifier is recommended for longer runs.

To split the data link into branches, use splitter-amplifiers in the connection line.

Do not overload the link. Up to 32 devices may be connected on a serial link.

## CONNECTION DAISY CHAIN

Connect the DMX data output from the DMX source to the product DMX input (male connector XLR) socket.

Run the data link from the product XLR output (female connector XLR) socket to the DMX input of the next fixture.

Terminate the data link by connecting a 120 Ohm signal termination. If a splitter is used, terminate each branch of the link.

Install a DMX termination plug on the last fixture on the link.

## CONNECTION OF THE DMX LINE

DMX connection employs standard XLR connectors. Use shielded pair-twisted cables with 120Ω impedance and low capacity.

The following diagram shows the connection mode:

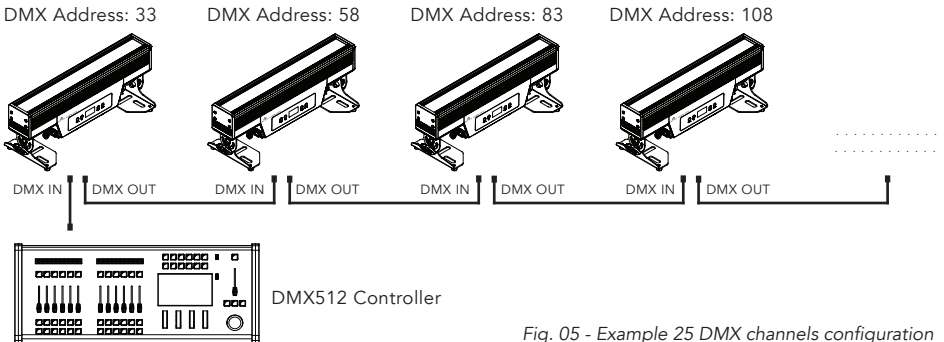

Fig. 05 - Example 25 DMX channels configuration

## CONSTRUCTION OF THE DMX TERMINATION

The termination is prepared by soldering a 120Ω 1/4 W resistor between pins 2 and 3 of the male XLR connector, as shown in figure.

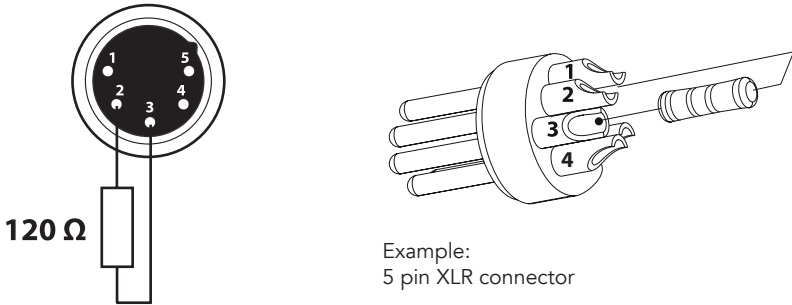

Fig. 06

## DMX ADDRESSING

In order to start controlling the product via DMX, the first step is to select a DMX address, also known as the start channel, this is the first channel used to receive instructions from a DMX controller. If you wish to control the product individually, it is necessary to assign a different starting address channel to each fixture.

The number of channels occupied from the product depends on the DMX mode selected, so always verify the DMX Mode in the MENU before start addressing.

If you assign two fixtures the same address, they will be executing the same behaviour. Selecting the same address to multiple fixtures can be useful for diagnostic purposes and symmetrical control.

DMX addressing is limited to make it impossible to set the DMX address so high that you are left without enough control channels for the product.

To set the fixture's DMX address:

1. Press ENTER to open the main menu.
2. Reach the addressing menu, then select the DMX ADDRESS settings.
3. Select the address from 1 to 512 using the navigation arrows/buttons and confirm by pressing ENTER.
4. Press Menu to exit and return to the Home screen.

## ETHERNET CONNECTION

The products is provided with two 8-pin RJ-45 sockets for Ethernet input/output for a simple daisy chain connection to the network.

The product can be controlled with ArtNet (or others available) communication protocol.

Use a network cable category 5 (with four "twisted" wire pairs) and standard RJ-45 plugs.

## ETHERNET OPERATION

Please refer to the section MENU STRUCTURE contained in this document for detailed informations about the parameters of setting on the fixture (Protocol, Net, Subnet, Universe, Start Channel and IP Address, Ethernet to DMX No/Yes).

- About the IP addresses is recommended to set 002.xxx.xxx.xxx or 010.xxx.xxx.xxx.
- The submask net is fixed at 255.0.0.0.

## ETHERNET TO DMX OPERATIONS

Please refer to the section MENU STRUCTURE contained in this document for detailed informations. This function allow a product receiving an ethernet signal protocol to re-transmit the incoming signal onto a wired DMX line through its onboard XLR-out connector.

- An Ethernet protocol (Artnet, sACN or others available) has to be enabled from Ethernet menu at first fixture. **Please make sure that wireless receiver is switched to OFF if you use Ethernet communication.**
- Enable the option Ethernet To DMX from the Ethernet menu at the first product (connected to the Ethernet) in the signal chain, next products have standard DMX setting.
- Connect the Ethernet input of the first product in the data chain with the network. Connect the DMX output of this product with the input of the next product until all products are connected to the DMX chain.
- Caution: At the last product, the DMX chain has to be terminated with a terminator. Solder a 120  $\Omega$  resistor between Signal (-) and Signal (+) into a XLR-plug and connect it in the DMX-output of the last product.

## OPERATION AS A WIRELESS TRANSMITTER

LUMIPIXXB050/100 can be used as wireless transmitter to transmit DMX signal to different wireless receivers. To use LUMIPIXXB050/100 as wireless transmitter, please follow the procedure below:

1. Push ENTER button until you show CONNECT on display, then press ENTER button to confirm.
2. Use UP/DOWN buttons for select WIRELESS, then press ENTER to confirm.
3. Push ENTER button on WDMX ON/OFF function and enable it to ON.
4. Select WDMX mode and set it on Transmitter (please note that WDMX mode will be available only if WDMX ON/OFF is set to ON).
5. Ensure that the receiver units are not connected to any other transmitter. Please refer to "Reset the receiver" paragraph.
6. Enable TX LINK to ON to link transmitter to receivers (please note that TX LINK will be available only if WDMX mode is set to Transmitter).
  - The transmitter scans for all unlinked receivers for a period of about 5 seconds.
  - If the connection fails, check the position of the receiver.
  - The wireless icon on the receiver display indicates the received signal strength.

## Unlinking the transmitter

Follow the procedure below to unlink the transmitter from all receivers connected with the unit.

1. Push ENTER button until you show CONNECT on display, then press ENTER button to confirm.
2. Use UP/DOWN buttons for select Wireless, then press ENTER to confirm.
3. Enable TX UNLINK to ON 8 (please note that TX UNLINK will be available only if WDMX mode is set to Transmitter).
  - All connected receivers will be unlinked.

## IN TO WDMX

This function enable or disable the transmission through wireless of the DMX signal from the transmitter side to the receiver.

Any incoming signal (ArtNet, sACN or DMX) is retransmitted through wireless.

If the LUMIPIXXB050/100 protocol selected is ArtNet / sACN, the WDMX module will retransmit the DMX values contained in the ArtNet / sACN signal received from the LUMIPIXXB050/100.

**NOTE:** Artnet and sACN have higher priority on DMX if they are connected to transmitter.

## **OPERATION AS A WIRELESS RECEIVER**

LUMIPIXXB050/100 can be used as wireless receiver connected to a wireless transmitter.

To use LUMIPIXXB050/100 as wireless receiver, please follow the procedure below:

1. Push ENTER button until you show CONNECT on display, then press ENTER button to confirm.
2. Use UP/DOWN buttons for select Wireless, then press ENTER to confirm.
3. Push ENTER button on WDMX ON/OFF function and enable it to ON.
4. Select WDMX mode and set it on Receiver (please note that WDMX mode will be available only if WDMX ON/OFF is set to ON).
5. Enable RX RESET to ON to reset the receiver (please note that RX RESET will be available only if WDMX mode is set to Receiver).
6. On the transmitter, enable TX LINK to ON to link transmitter to the receivers.
7. If the connection is successful and DMX input is available the display the display on the receiver unit will shows the DMX address. If DMX signal is not available, the display will shows "No signal" but keeps the transmitter linked.
8. If the connection fails, check the position of the receiver.
9. The wireless icon on the receiver display indicates the received signal strength.

### **Reset the receiver**

Follow the procedure below to reset the receiver.

1. Push MENU button until you show CONNECT on display, then press ENTER button to confirm.
2. Use UP/DOWN buttons for select Wireless, then press ENTER to confirm.
3. Enable RX RESET to ON.
  - The wireless icon on the receiver display indicates the received signal strength.

### **WDMX TO DMX (RX)**

This function enable or disable the retransmission of the wireless DMX signal received through the DMX port on the receiver side.

## 8 - CONTROL PANEL

The product has a display and buttons for access to the control panel functions.

---

### LumiPix XB050

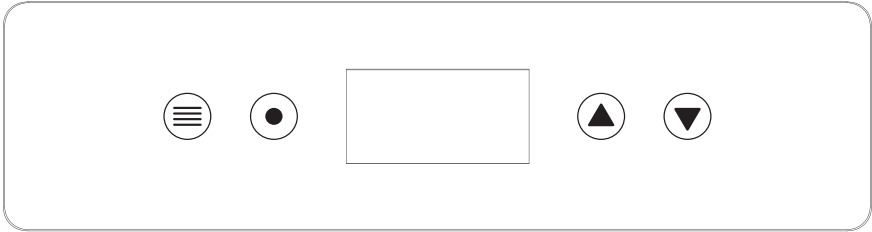





Fig. 07

---

#### DISPLAY AND BUTTONS LAYOUT

The product has a display and buttons for access to the control panel functions:

	Used to access the menu tree or to return a previous menu window.
	Browse upwards through the menu list and increases the numeric value displayed.
	Browse downwards through the menu list and decreases the numeric value displayed.
	Used to confirm the current menu or confirm the current function value or option within a menu.

# 9 - MENU STRUCTURE

The following chart describes the MENU tree of the product, the terms shown in **BOLD** indicates the default settings.

1	CONNECT	DMX ADDRESS	<table border="1"> <tr> <td>DMX</td> <td rowspan="4">1-512</td> <td rowspan="4"></td> <td rowspan="4"></td> <td rowspan="4">Set DMX Address for Main fixture.</td> </tr> <tr> <td>WDMX</td> </tr> <tr> <td>ARTNET</td> </tr> <tr> <td>SACN</td> </tr> </table>	DMX	1-512			Set DMX Address for Main fixture.	WDMX	ARTNET	SACN																																																																																								
	DMX	1-512							Set DMX Address for Main fixture.																																																																																										
WDMX																																																																																																			
ARTNET																																																																																																			
SACN																																																																																																			
		PIXELS	<table border="1"> <tr> <td><b>FOLLOW FIXTURE</b></td> <td rowspan="10">1-512</td> <td rowspan="10"></td> <td rowspan="10"></td> <td rowspan="10">Set DMX Address for Pixel Engine.</td> </tr> <tr> <td>DMX</td> </tr> <tr> <td>WDMX</td> </tr> <tr> <td>sACN</td> </tr> <tr> <td>ARTNET</td> </tr> <tr> <td>KLINGNET</td> </tr> <tr> <td>sACN+ARTNET</td> </tr> <tr> <td>sACN+KLINGNET</td> </tr> <tr> <td>ARTNET+KLINGNET</td> </tr> </table>	<b>FOLLOW FIXTURE</b>	1-512			Set DMX Address for Pixel Engine.	DMX	WDMX	sACN	ARTNET	KLINGNET	sACN+ARTNET	sACN+KLINGNET	ARTNET+KLINGNET																																																																																			
<b>FOLLOW FIXTURE</b>	1-512			Set DMX Address for Pixel Engine.																																																																																															
DMX																																																																																																			
WDMX																																																																																																			
sACN																																																																																																			
ARTNET																																																																																																			
KLINGNET																																																																																																			
sACN+ARTNET																																																																																																			
sACN+KLINGNET																																																																																																			
ARTNET+KLINGNET																																																																																																			
					DMX MODE	<table border="1"> <tr> <td>FIXTURE</td> <td>UNO</td> <td>SOURCE EMULATION</td> <td>REFER TO STATIC MODE INTO STANDALONE</td> <td rowspan="20">Set DMX mode for fixture Engine.</td> </tr> <tr> <td></td> <td></td> <td>COLOR TEMPERATURE</td> <td> <table border="1"> <tr><td>2800K</td></tr> <tr><td>3200K</td></tr> <tr><td>3500K</td></tr> <tr><td>4000K</td></tr> <tr><td>4500K</td></tr> <tr><td>5000K</td></tr> <tr><td>5600K</td></tr> <tr><td>6000K</td></tr> <tr><td>6500K</td></tr> <tr><td>7000K</td></tr> <tr><td>7500K</td></tr> <tr><td>8000K</td></tr> <tr><td>8500K</td></tr> <tr><td>9000K</td></tr> <tr><td>9500K</td></tr> <tr><td>10000K</td></tr> </table> </td> </tr> <tr> <td></td> <td></td> <td>COLOR MACRO</td> <td>SEE TABLE OF COLOR MACRO</td> </tr> <tr> <td></td> <td></td> <td>MANUAL COLORS</td> <td> <table border="1"> <tr><td>RED</td><td>&lt;000-255&gt;</td></tr> <tr><td>GREEN</td><td>&lt;000-255&gt;</td></tr> <tr><td>BLUE</td><td>&lt;000-255&gt;</td></tr> <tr><td>WARM WHITE</td><td>&lt;000-255&gt;</td></tr> </table> </td> </tr> <tr> <td></td> <td></td> <td>DUO</td> <td>SAME SETTINGS OF "UNO"</td> </tr> <tr> <td></td> <td></td> <td>BASIC</td> <td> <table border="1"> <tr><td>RGBW</td></tr> <tr><td>RGB</td></tr> <tr><td>CMY</td></tr> <tr><td>HSI</td></tr> </table> </td> </tr> <tr> <td></td> <td></td> <td><b>STANDARD</b></td> <td> <table border="1"> <tr><td><b>RGBW</b></td></tr> <tr><td>RGB</td></tr> <tr><td>CMY</td></tr> <tr><td>HSI</td></tr> </table> </td> </tr> <tr> <td></td> <td></td> <td>EXTENDED</td> <td> <table border="1"> <tr><td>RGBW</td></tr> <tr><td>RGB</td></tr> <tr><td>CMY</td></tr> <tr><td>HSI</td></tr> </table> </td> </tr> <tr> <td></td> <td></td> <td>FX</td> <td> <table border="1"> <tr><td>FX CINE</td></tr> <tr><td>FX TOUR</td></tr> <tr><td>FX EXTENDED</td></tr> </table> </td> </tr> <tr> <td></td> <td></td> <td>XY</td> <td></td> </tr> <tr> <td></td> <td></td> <td>DIRECT 8 BIT</td> <td></td> </tr> <tr> <td></td> <td></td> <td>DIRECT 16 BIT</td> <td></td> </tr> <tr> <td></td> <td></td> <td>THEATER</td> <td> <table border="1"> <tr><td>4Ch</td></tr> <tr><td>5Ch1</td></tr> <tr><td>5Ch2</td></tr> <tr><td>6Ch</td></tr> <tr><td>10Ch</td></tr> </table> </td> </tr> </table>	FIXTURE	UNO	SOURCE EMULATION	REFER TO STATIC MODE INTO STANDALONE	Set DMX mode for fixture Engine.			COLOR TEMPERATURE	<table border="1"> <tr><td>2800K</td></tr> <tr><td>3200K</td></tr> <tr><td>3500K</td></tr> <tr><td>4000K</td></tr> <tr><td>4500K</td></tr> <tr><td>5000K</td></tr> <tr><td>5600K</td></tr> <tr><td>6000K</td></tr> <tr><td>6500K</td></tr> <tr><td>7000K</td></tr> <tr><td>7500K</td></tr> <tr><td>8000K</td></tr> <tr><td>8500K</td></tr> <tr><td>9000K</td></tr> <tr><td>9500K</td></tr> <tr><td>10000K</td></tr> </table>	2800K	3200K	3500K	4000K	4500K	5000K	5600K	6000K	6500K	7000K	7500K	8000K	8500K	9000K	9500K	10000K			COLOR MACRO	SEE TABLE OF COLOR MACRO			MANUAL COLORS	<table border="1"> <tr><td>RED</td><td>&lt;000-255&gt;</td></tr> <tr><td>GREEN</td><td>&lt;000-255&gt;</td></tr> <tr><td>BLUE</td><td>&lt;000-255&gt;</td></tr> <tr><td>WARM WHITE</td><td>&lt;000-255&gt;</td></tr> </table>	RED	<000-255>	GREEN	<000-255>	BLUE	<000-255>	WARM WHITE	<000-255>			DUO	SAME SETTINGS OF "UNO"			BASIC	<table border="1"> <tr><td>RGBW</td></tr> <tr><td>RGB</td></tr> <tr><td>CMY</td></tr> <tr><td>HSI</td></tr> </table>	RGBW	RGB	CMY	HSI			<b>STANDARD</b>	<table border="1"> <tr><td><b>RGBW</b></td></tr> <tr><td>RGB</td></tr> <tr><td>CMY</td></tr> <tr><td>HSI</td></tr> </table>	<b>RGBW</b>	RGB	CMY	HSI			EXTENDED	<table border="1"> <tr><td>RGBW</td></tr> <tr><td>RGB</td></tr> <tr><td>CMY</td></tr> <tr><td>HSI</td></tr> </table>	RGBW	RGB	CMY	HSI			FX	<table border="1"> <tr><td>FX CINE</td></tr> <tr><td>FX TOUR</td></tr> <tr><td>FX EXTENDED</td></tr> </table>	FX CINE	FX TOUR	FX EXTENDED			XY				DIRECT 8 BIT				DIRECT 16 BIT				THEATER	<table border="1"> <tr><td>4Ch</td></tr> <tr><td>5Ch1</td></tr> <tr><td>5Ch2</td></tr> <tr><td>6Ch</td></tr> <tr><td>10Ch</td></tr> </table>	4Ch
FIXTURE	UNO	SOURCE EMULATION	REFER TO STATIC MODE INTO STANDALONE	Set DMX mode for fixture Engine.																																																																																															
		COLOR TEMPERATURE	<table border="1"> <tr><td>2800K</td></tr> <tr><td>3200K</td></tr> <tr><td>3500K</td></tr> <tr><td>4000K</td></tr> <tr><td>4500K</td></tr> <tr><td>5000K</td></tr> <tr><td>5600K</td></tr> <tr><td>6000K</td></tr> <tr><td>6500K</td></tr> <tr><td>7000K</td></tr> <tr><td>7500K</td></tr> <tr><td>8000K</td></tr> <tr><td>8500K</td></tr> <tr><td>9000K</td></tr> <tr><td>9500K</td></tr> <tr><td>10000K</td></tr> </table>		2800K	3200K	3500K	4000K	4500K	5000K		5600K	6000K	6500K	7000K	7500K	8000K	8500K	9000K	9500K	10000K																																																																														
2800K																																																																																																			
3200K																																																																																																			
3500K																																																																																																			
4000K																																																																																																			
4500K																																																																																																			
5000K																																																																																																			
5600K																																																																																																			
6000K																																																																																																			
6500K																																																																																																			
7000K																																																																																																			
7500K																																																																																																			
8000K																																																																																																			
8500K																																																																																																			
9000K																																																																																																			
9500K																																																																																																			
10000K																																																																																																			
		COLOR MACRO	SEE TABLE OF COLOR MACRO																																																																																																
		MANUAL COLORS	<table border="1"> <tr><td>RED</td><td>&lt;000-255&gt;</td></tr> <tr><td>GREEN</td><td>&lt;000-255&gt;</td></tr> <tr><td>BLUE</td><td>&lt;000-255&gt;</td></tr> <tr><td>WARM WHITE</td><td>&lt;000-255&gt;</td></tr> </table>		RED	<000-255>	GREEN	<000-255>	BLUE	<000-255>	WARM WHITE	<000-255>																																																																																							
RED	<000-255>																																																																																																		
GREEN	<000-255>																																																																																																		
BLUE	<000-255>																																																																																																		
WARM WHITE	<000-255>																																																																																																		
		DUO	SAME SETTINGS OF "UNO"																																																																																																
		BASIC	<table border="1"> <tr><td>RGBW</td></tr> <tr><td>RGB</td></tr> <tr><td>CMY</td></tr> <tr><td>HSI</td></tr> </table>	RGBW	RGB	CMY	HSI																																																																																												
RGBW																																																																																																			
RGB																																																																																																			
CMY																																																																																																			
HSI																																																																																																			
		<b>STANDARD</b>	<table border="1"> <tr><td><b>RGBW</b></td></tr> <tr><td>RGB</td></tr> <tr><td>CMY</td></tr> <tr><td>HSI</td></tr> </table>	<b>RGBW</b>	RGB	CMY	HSI																																																																																												
<b>RGBW</b>																																																																																																			
RGB																																																																																																			
CMY																																																																																																			
HSI																																																																																																			
		EXTENDED	<table border="1"> <tr><td>RGBW</td></tr> <tr><td>RGB</td></tr> <tr><td>CMY</td></tr> <tr><td>HSI</td></tr> </table>	RGBW	RGB	CMY	HSI																																																																																												
RGBW																																																																																																			
RGB																																																																																																			
CMY																																																																																																			
HSI																																																																																																			
		FX	<table border="1"> <tr><td>FX CINE</td></tr> <tr><td>FX TOUR</td></tr> <tr><td>FX EXTENDED</td></tr> </table>	FX CINE	FX TOUR	FX EXTENDED																																																																																													
FX CINE																																																																																																			
FX TOUR																																																																																																			
FX EXTENDED																																																																																																			
		XY																																																																																																	
		DIRECT 8 BIT																																																																																																	
		DIRECT 16 BIT																																																																																																	
		THEATER	<table border="1"> <tr><td>4Ch</td></tr> <tr><td>5Ch1</td></tr> <tr><td>5Ch2</td></tr> <tr><td>6Ch</td></tr> <tr><td>10Ch</td></tr> </table>	4Ch	5Ch1	5Ch2	6Ch	10Ch																																																																																											
4Ch																																																																																																			
5Ch1																																																																																																			
5Ch2																																																																																																			
6Ch																																																																																																			
10Ch																																																																																																			



				15Ch			
				17Ch			
				21Ch			
			PIXEL (LUMIPIXXB050)	1 Pix			
				3 Pix			
				9 Pix			
			PIXEL (LUMIPIXXB100)	1 Pix			
				3 Pix			
				6 Pix			
				18 Pix			
			FILM	1M12CH			
				2M20CH			
		<b>PIXELS</b> (LUMIPIXXB050)	<b>OFF</b>				Set DMX mode for Pixel Engine.
			9PX				
			EXTENDED				
		<b>PIXELS</b> (LUMIPIXXB100)	<b>OFF</b>				
			18PX				
			EXTENDED				
WIRELESS	WDMX ON/OFF		ON				Enable/Disable the wireless card.
			OFF				
	WDMX MODE		TRANSMITTER				Choose whether to set the wireless card as Transmitter or Receiver. WDMX mode is unlocked only if WDMX ON / OFF is ON.
			<b>RECEIVER</b>				
	TX LINK		ON				TX link unlock when the unit is set as a transmitter.
			OFF				
	TX UNLINK		ON				Disconnect the transmitter from all receivers. TX unlink unlocks only if WDMX mode is on transmitter.
			OFF				
	RX RESET		ON				Total reset of the receiver. RX reset unlocks only if WDMX mode is receiver.
			OFF				
In To WDMX (TX)		ON				Enable/Disable the transmission of the dmX from the transmitter to the receiver via wdmx.	
		OFF					
WDMX To DMX (RX)		ON				Enable/Disable the retransmission of the DMX from the receiver to the other units connected by cable to the receiver itself.	
		OFF					
ETHERNET SETTINGS	ARTNET SETTINGS	FIXTURE	IP ADDRESS	xxx.xxx.xxx.xxx			Settings for ArtNet protocol use.
			NET	0-127			
			SUBNET	0-15			
			SUBNET MASK				
		UNIVERSE	0-15				
		PIXELS	IP ADDRESS	xxx.xxx.xxx.xxx			
			NET	0-127			
			SUBNET	0-15			
	SUBNET MASK						
	UNIVERSE	0-15					
	sACN SETTINGS	FIXTURE	IP ADDRESS	xxx.xxx.xxx.xxx			Settings for sACN protocol use.
			UNIVERSE	1-16			
			MERGE MODE	OFF			
				HTP			
		LTP					
		PIXELS	IP ADDRESS	xxx.xxx.xxx.xxx			
			UNIVERSE	1-16			
			MERGE MODE	OFF			
	HTP						
	LTP						
Ethernet to WDMX		ON				Enable / Disable DMX retransmission from sACN/ ArtNet signal to WDMX (TX mode).	
		OFF					
Ethernet to DMX		ON				Enable / Disable DMX retransmission from sACN/ ArtNet signal to DMX out port.	
		OFF					

2	SETUP	SCREEN	Backlight	ON			Select the timing after that display will switch automatically off when unactive.		
				10S					
				20S					
				FLIP DISPLAY	OFF				Allows you to rotate the display by 180°.
				KEY LOCK	ON				Lock the buttons on the control panel by a password. Press following combinations (password) in order to access to the user menu : UP, DOWN, UP, DOWN, ENTER.
			OFF						
			DISPLAY VALUE	RAW DATA				Choose how to show datas on Stand Alone Modes. In percentage mode values will be shown as 0-100%. In Raw Data mode values will be shown as 0-255.	
				PERCENTAGE					
			TEMPERATURE UNIT	°C				Allows you to choose Temperature unit showed in home screen.	
				°F					
		USER SETTINGS	PRESET 1 TO 5	RECALL					
	SAVE								
	MOVE								
			SET AS DEFAULT						
	TRANSFER CONFIGURATION	WITHOUT DMX ADDRESS					To transfer the same menu settings of one fixtures to all the other in the daisy chain, including or not the dmx address.		
		WITH DMX ADDRESS							
3	ADVANCED	CALIBRATION	ON				Enable/Disable Spektra Calibration		
			OFF						
		DIMMER CURVE	LINEAR				Choose dimmer curve.		
			S-CURVE						
			SQUARE LAW						
			INVERSE SQUARE LAW						
			HIGH RES@LOW						
		DIMMER SPEED	AUTO				Set Dimmer Speed. This parameter defines interpolation of DMX Changes for main functions. Off turns off interpolation		
			FAST						
			MEDIUM						
			SLOW						
		DIMMER END	FADE OFF@END				Set Dimmer End behaviour. Snap Off will make fixture snap when dimming out to 0. Fade Off will make fixture fade when dimming out to 0. This selection affects only 004-000 DMX value behaviour.		
			SNAP OFF@END						
		LED FREQUENCY	600Hz				Select PWM frequency.		
			1200Hz						
			2000Hz						
			4000Hz						
			6000Hz						
			10kHz						
			12kHz						
			15kHz						
			20kHz						
			25kHz						
			36kHz						
		40kHz							
		DMX FAULT	HOLD						
			BLACKOUT						
STAND ALONE									
EMERGENCY									
INVERT MAPPING	ON								
	OFF								

	FAN MODE	CONSTANT OUTPUT	AUTO / HIGH / SILENT 1 / SILENT 2 / OFF				Select the product Fan mode for Standard mode. Constant Output: fixture will decrease immediately light output. Note: fixture will lower light output in case of Silent1, Silent2 and OFF. Dynamic Output: fixture will have variable light output in order to keep a safe running temperature.
		DYNAMIC OUTPUT	AUTO / HIGH / SILENT 1 / SILENT 2 / OFF				
	TUNGSTEN EMULATION	OFF					
		AUTO					
		FAST					
		MEDIUM					
		SLOW					
	FACTORY RELOAD	STANDARD	ON - OFF				Reload fixture with Standard settings.
		USER PRESET	ON - OFF				Reload fixture with User Preset.
4	INFORMATION	DEVICE TIME	FIXTURE HOURS	<99999H>			
			CURRENT HOURS	<99999H>			
			SOURCE HOURS	<99999H>			
			AC POWER ON CYCLE	<300>			
		MAINTENANCE TIME	ELAPSED TIME				
	ALERT PERIOD		10 - 1000				
	TEMPERATURE						Show temperature for each LED PCB.
	WIRELESS QUALITY						
	CHANNEL VALUE						
	ERROR MESSAGE						Refer to Troubleshooting section for Error details.
	FIXTURE MODEL						
	DEVICE LABEL						
	SOFTWARE VERSION	<V1.0>					Show software version for each PCB.
	RDM UID	15D00228****					View the UID of the product (RDM control).
5	STAND ALONE	MASTER/SLAVE	MASTER DMX				Allow you to link and operating in synk multiple units without a DMX console. Choose a unit to perform as the Master. Master No DMX: fixture is not broadcasting signal
			MASTER NO DMX				
			SLAVE				
	CINE FX	Party Effect					
		Candle					
		Clouds Passing					
		Club Lights					
		Color Chase					
		Cop Car					
		Fire					
		Fireworks					
		Strobe					
		Lightning					
		Paparazzi					
		Pulsing					
		Television					
		Explosion					
	Fluorescent Flicker						
	Process Effect						
	Welding						
TOUR FX	FX 1-23	PATTERN SPEED					
		PATTERN FADE					
		F.G. INTENSITY					
		F.G. STROBE					
		F.G. RED					
		F.G. GREEN					
		F.G. BLUE					

			F.G. WARM WHITE			
			F.G. INTENSITY			
			F.G. STROBE			
			F.G. RED			
			F.G. GREEN			
			F.G. BLUE			
			F.G. WARM WHITE			
	SOURCE EMULATION	DIMMER	0 - 255			
		INCANDESCENT	Tungsten Bulb Incandescent Halogen Antique Bulb Warm Antique Bulb Christmas Lights Night Light Infrared Heat Lamp Grow light			
		FLUORESCENT	CFL Soft White CFL Bright White CFL Cool White CFL Daylight Cool White 1 Cool White 2 Cool White 3 Warm White CFL Blacklight			
		DISCHARGE	HMI High Pressure Sodium Low Pressure Sodium Mercury Vapor Metal Halide Ceramic Carbon Arc Xenon			
		OTHER	Candle Gas Fire Sun Direct Sun Overcast Sun Blue Hour Mobile Phone Computer Monitor Electroluminescence Blow Torch Road Flare Amber Caution Green Traffic Light Yellow Traffic Light Red Traffic Light Blue Glow Stick Green Glow Stick Red Glow Stick Yellow Glow Stick Pink Glow Stick Violet Glow Stick			
	CCT	Dimmer, CCT, Tint				
	HSI	Hue, Saturation, Intensity				
	FIXED COLORS	R G B W RG RB RW GB GW BW RGB RGW RBW GBW RGBW				Select of the following pre-defined color combination and its Dimmer value. After enabled this mode, the unit will be automatically assigned as Master.

	WHITE PRESETS	2800K 3200K 3500K 4000K 4500K 5000K 5600K 6000K 6500K 7000K 7500K 8000K 8500K 9000K 9500K 10000K					
	COLOR MACRO	DIMMER	0 - 255				
		LEE	Color Correction Color Filters 600 Series Cosmetic 700 Series				
		COLOR	Correction CColor SSelection Lux				
	MANUAL COLORS						
	XY						
	USER PRESET						

## 10 - SHORTCUT

SHORTCUTS		
Keys	Mode	Description
UP + DOWN after power on	Flip Display	Directly flip display without enter inside menu
ENTER	Standalone Mode	Direct access to Standalone menu

# 11 - RDM FUNCTIONS

The product can communicate using RDM (Remote Device Management) protocol over a DMX512 Networks.

RDM is a bi-directional communications protocol for use in DMX512 control systems, it is the open standard for DMX512 device configuration and status monitoring.

The RDM protocol allows data packets to be inserted into a DMX512 data stream without affecting existing non-RDM equipment. It allows a console or dedicated RDM controller to send commands to and receive messages from specific fixtures.

The PIDs in the following tables are supported in the product.

RDM is also available on Wireless and Tiny's Downstead must be enabled in its custom PIDs to work.

RDM PIDs							
Parameter	Category	PID Address	GET	SET	Value	Description	Default Value
DEVICE_INFO	Product Information	0x0060	x		---	N/A	
PRODUCT_DETAIL_ID_LIST	Product Information	0x0070	x		---	N/A	
DEVICE_MODEL_DESCRIPTION	Product Information	0x0080	x		---	N/A	x
MANUFACTURER_LABEL	Product Information	0x0081	x		---	N/A	
DEVICE_LABEL	Product Information	0x0082	x	x	---	N/A	
FACTORY_DEFAULTS	Product Information	0x0090	x	x	---	N/A	
SOFTWARE_VERSION_LABEL	Product Information	0x00C0	x		---	N/A	
BOOT_SOFTWARE_VERSION_ID	Product Information	0x00C1	x		---	N/A	
BOOT_SOFTWARE_VERSION_LABEL	Product Information	0x00C2	x		---	N/A	x
DMX_PERSONALITY	DMX512 Setup	0x00E0	x	x	---	N/A	
DMX_PERSONALITY_DESCRIPTION	DMX512 Setup	0x00E1	x		---	N/A	
DMX_START_ADDRESS	DMX512 Setup	0x00F0	x	x	---	N/A	
SLOT_INFO	DMX512 Setup	0x0120	x		---	N/A	
SLOT_DESCRIPTION	DMX512 Setup	0x0121	x		---	N/A	
DEFAULT_SLOT_VALUE	DMX512 Setup	0x0122	x		---	N/A	
DMX_BLOCK_ADDRESS	DMX512 Setup	0x0140	x	x	---	N/A	x*
DMX_FAIL_MODE	DMX512 Setup	0x0141	x	x	---	N/A	
DMX_STARTUP_MODE	DMX512 Setup	0x0142	x	x	---	N/A	

RDM PIDs							
Parameter	Category	PID Address	GET	SET	Value	Description	Default Value
DIMMER_INFO	Dimmer Settings	0x0340	x		---	N/A	
MINIMUM_LEVEL	Dimmer Settings	0x0341	x	x	---	N/A	
MAXIMUM_LEVEL	Dimmer Settings	0x0342	x	x	---	N/A	
CURVE	Dimmer Settings	0x0343	x	x	---	N/A	
CURVE_DESCRIPTION	Dimmer Settings	0x0344	x	x	---	N/A	
OUTPUT_RESPONSE_TIME	Dimmer Settings	0x0345	x	x	---	N/A	
OUTPUT_RESPONSE_TIME_DESCRIPTION	Dimmer Settings	0x0346	x		---	N/A	
MODULATION_FREQUENCY	Dimmer Settings	0x0347	x	x	---	N/A	
MODULATION_FREQUENCY_DESCRIPTION	Dimmer Settings	0x0348	x		---	N/A	
SENSOR_DEFINITION	Sensors	0x0200	x		---	N/A	
SENSOR_VALUE	Sensors	0x0201	x	x	---	N/A	x*
RECORD_SENSORS	Sensors	0x0202		x	---	N/A	
BURN_IN	Sensors	0x0440	x	x	---	N/A	x*
DEVICE_HOURS	Power/Lamp Settings	0x0400	x	x	---	N/A	
LAMP_HOURS	Power/Lamp Settings	0x0401	x	x	---	N/A	x*
LAMP_STRIKES	Power/Lamp Settings	0x0402	x	x	---	N/A	
LAMP_STATE	Power/Lamp Settings	0x0403	x	x	---	N/A	
LAMP_ON_MODE	Power/Lamp Settings	0x0404	x	x	---	N/A	
DEVICE_POWER_CYCLES	Power/Lamp Settings	0x0405	x	x	---	N/A	
DISPLAY_INVERT	Display Settings	0x0500	x	x	---	N/A	
DISPLAY_LEVEL	Display Settings	0x0501	x	x	---	N/A	
LOCK_PIN	Configuration	0x0640	x	x	---	N/A	
LOCK_STATE	Configuration	0x0641	x	x	---	N/A	
LOCK_STATE_DESCRIPTION	Configuration	0x0642	x		---	N/A	
IDENTIFY_DEVICE	Control	0x1000	x	x	---	N/A	
RESET_DEVICE	Control	0x1001		x	---	N/A	
POWER_STATE	Control	0x1010	x	x	---	N/A	
PERFORM_SELFTEST	Control	0x1020	x	x	---	N/A	
SELF_TEST_DESCRIPTION	Control	0x1021	x		---	N/A	
CAPTURE_PRESET	Control	0x1030	x	x	---	N/A	
PRESET_PLAYBACK	Control	0x1031	x	x	---	N/A	

RDM PIDs							
Parameter	Category	PID Address	GET	SET	Value	Description	Default Value
IDENTIFY_MODE	Control	0x1040	x	x	---	N/A	
PRESET_INFO	Control	0x1041	x		---	N/A	
PRESET_STATUS	Control	0x1042	x	x	---	N/A	
POWER_ON_SELF_TEST	Control	0x1044	x	x	---	N/A	
PIXEL MODE 0:OFF 1:4PX 2:EXT	Manufacturer PIDs		x	x		PIXEL MODE 0:OFF 1:4PX 2:EXT	
0-7 W/DMX-SA-AN-KN-SK-AK-S+A-FF	Manufacturer PIDs		x	x		PIXEL PROT 0:W/DMX 1:SACN 2:ARTN 3:KN 4:SK 5:AK 6:SA 7:FF	
PIXEL ADDR 0-512	Manufacturer PIDs		x	x		PIXEL ADDR 0-512	
INVERT MAPPING 0:OFF 1:ON	Manufacturer PIDs		x	x		INVERT MAPPING 0:OFF 1:ON	DEFAULT: OFF
DMX FAULT	Manufacturer PIDs		x	x		0: HOLD 1: BLCK 2:SA 3:EMGENCY	DEFAULT: 2
TUNGSTEN EMULATION	Manufacturer PIDs		x	x		0:OFF: 1:AUTO 2:FAST 3:MED 4:SLW	DEFAULT: 0
MASTER/SLAVE	Manufacturer PIDs		x	x		0:MST DMX 1:MST NO DMX 2:SLAVE	DEFAULT:2
ST. AL. MODE	Manufacturer PIDs		x	x		0-6:FX-CCT-HSI-FIX-WH-MC-MNL	DEFAULT:2
EFFECTS	Manufacturer PIDs		x	x		1 to 26	DEFAULT:1
EFFECTS SPEED	Manufacturer PIDs		x	x		1-60000	
EFFECTS FADE	Manufacturer PIDs		x	x		0-60000	
FIXED COLORS	Manufacturer PIDs		x	x	1-15		DEFAULT: RGBW
COLOR MACRO	Manufacturer PIDs		x	x	1-67		
WHITE PRESETS	Manufacturer PIDs		x	x	1-14		DEFAULT: 5600K
STATIC RED	Manufacturer PIDs		x	x	0-255		DEFAULT: 255
STATIC GREEN	Manufacturer PIDs		x	x	0-255		DEFAULT: 255



RDM PIDs							
Parameter	Category	PID Address	GET	SET	Value	Description	Default Value
STATIC BLUE	Manufacturer PIDs		x	x	0-255		DEFAULT: 255
STATIC WHITE	Manufacturer PIDs		x	x	0-255		DEFAULT: 255
CALIBRATION	Manufacturer PIDs		x	x	0-1	0: OFF 1: STD 2: MNL 3: CALIBR	DEFAULT: CALIBR
WIRELESS QUALITY	Manufacturer PIDs		x			**%	
ERROR MESSAGE	Manufacturer PIDs		x				
FACTORY DEFAULT 0:STD 1:USER	Manufacturer PIDs		x	x		0:STD 1:USER	DEFAULT: switching
SETTINGS SELECTOR: 1 TO 5	Manufacturer PIDs		x	x		USER SETTING 0-4	

# 12 - DMX CHARTS

LUMIPIXB050 RDM Model ID: 0xD103  
RDM Personality ID List

ID	DMX Mode	Footprint
1	UNO	1
2	DUO	2
3	BASIC	19
4	STANDARD	23
5	EXTENDED	43
6	FX CINE	13
7	FX TOUR	20
8	FX EXTENDED	33
9	DIRECT 8 BIT	14
10	DIRECT 16 BIT	18
11	XY	19
12	THEATER 4Ch	4
13	THEATER 5Ch1	5
14	THEATER 5Ch2	5
15	THEATER 6Ch	6
16	THEATER 10Ch	10
17	THEATER 15Ch	15
18	THEATER 17Ch	17
19	THEATER 21Ch	21
20	1 PIX	4
21	3 PIX	12
22	9 PIX	36
23	FILM 1M	12
24	FILM 2M	20

**LUMIPIXB100 RDM Model ID: 0xD102****RDM Personality ID List**

<b>ID</b>	<b>DMX Mode</b>	<b>Footprint</b>
1	UNO	1
2	DUO	2
3	BASIC	19
4	STANDARD	23
5	EXTENDED	43
6	FX CINE	13
7	FX TOUR	20
8	FX EXTENDED	33
9	DIRECT 8 BIT	14
10	DIRECT 16 BIT	18
11	XY	19
12	THEATER 4Ch	4
13	THEATER 5Ch1	5
14	THEATER 5Ch2	5
15	THEATER 6Ch	6
16	THEATER 10Ch	10
17	THEATER 15Ch	15
18	THEATER 17Ch	17
19	THEATER 21Ch	21
20	1 PIX	4
21	3 PIX	12
22	6 PIX	24
23	18 PIX	72
24	FILM 1M	12
25	FILM 2M	20

# FIXTURE DMX CHARTS

NOTE: Refer to channel definitions for dependencies list.

## PIXEL LAYOUT

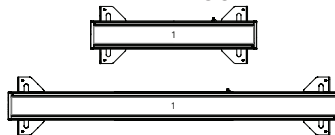

### FIXTURE

PARAMETER	MODE										
	UNO	DUO	BASIC	STAND- ARD	EXTENDED	FX Cine	FX Tour	FX AD- VANCED	DIRECT 8 BIT	DIRECT 16 BIT	XY
DIMMER	1	1	1	1	1	1	1	1	1	1	1
DIMMER FINE	-	2	2	2	2	2	2	2	2	2	2
STROBE	-	-	3	3	3	3	3	3	3	3	3
X 1	-	-	-	-	-	-	-	-	-	-	6
X 1 FINE	-	-	-	-	-	-	-	-	-	-	7
Y 1	-	-	-	-	-	-	-	-	-	-	8
Y 1 FINE	-	-	-	-	-	-	-	-	-	-	9
X 2	-	-	-	-	-	-	-	-	-	-	11
X 2 FINE	-	-	-	-	-	-	-	-	-	-	12
Y 2	-	-	-	-	-	-	-	-	-	-	13
Y 2 FINE	-	-	-	-	-	-	-	-	-	-	14
COLOR 1	-	-	4	4	4	-	-	-	7	7	-
COLOR 1 FINE	-	-	5	5	5	-	-	-	-	8	-
COLOR 2	-	-	6	6	6	-	-	-	8	9	-
COLOR 2 FINE	-	-	7	7	7	-	-	-	-	10	-
COLOR 3	-	-	8	8	8	-	-	-	9	11	-
COLOR 3 FINE	-	-	9	9	9	-	-	-	-	12	-
COLOR 4	-	-	10	10	10	-	-	-	10	13	-
COLOR 4 FINE	-	-	11	11	11	-	-	-	-	14	-
COLOR MACRO BRAND	-	-	12	12	-	-	-	-	11	15	15
COLOR MACRO CATEGORY	-	-	13	13	-	-	-	-	12	16	16
COLOR MACRO	-	-	14	14	-	-	-	-	13	17	17
CCT	-	-	15	15	12	-	-	4	4	4	4
CROSSFADE FROM ETH1 TO ETH2	-	-	16	16	13	-	-	-	-	-	-
CROSSFADE FOR PIXEL ENGINE	-	-	17	17	14	-	-	-	-	-	-
CROSSFADE FROM WHITE TO COLOR	-	-	18	18	15	-	-	6	6	6	-
CROSSFADE FROM X/Y 1 LAYER TO X/Y 2 LAYER	-	-	-	-	-	-	-	-	-	-	10
CONTROL	-	-	19	19	16	4	4	8	14	18	19
CTO ON COLORS	-	-	-	20	17	-	-	7	-	-	18
TINT	-	-	-	21	18	-	-	5	5	5	5
SOURCE EMULATION CATEGORY	-	-	-	22	-	-	-	-	-	-	-
SOURCE EMULATION MACRO	-	-	-	23	-	-	-	-	-	-	-
CONTROL MODE SELECTOR	-	-	-	-	19	5	-	9	-	-	-
CINEMA FX SELECTOR	-	-	-	-	20	6	-	10	-	-	-
PARAMETER 1	-	-	-	-	21	7	-	11	-	-	-
PARAMETER 2	-	-	-	-	22	8	-	12	-	-	-
PARAMETER 3	-	-	-	-	23	9	-	13	-	-	-
PARAMETER 4	-	-	-	-	24	10	-	14	-	-	-
PARAMETER 5	-	-	-	-	25	11	-	15	-	-	-
PARAMETER 6	-	-	-	-	26	12	-	16	-	-	-
PARAMETER 7	-	-	-	-	27	13	-	17	-	-	-
TOUR FX SELECTOR	-	-	-	-	28	-	5	18	-	-	-
TOUR PATTERN SPEED	-	-	-	-	29	-	6	19	-	-	-
TOUR PATTERN FADE	-	-	-	-	30	-	7	20	-	-	-
TOUR PATTERN TRANSITION	-	-	-	-	31	-	8	21	-	-	-
TOUR FOREGROUND INTENSITY	-	-	-	-	32	-	9	22	-	-	-
TOUR FOREGROUND STROBE	-	-	-	-	33	-	10	23	-	-	-
TOUR FOREGROUND RED	-	-	-	-	34	-	11	24	-	-	-

**FIXTURE**

**MODE**

PARAMETER	MODE										
	UNO	DUO	BASIC	STAND- ARD	EXTENDED	FX Cine	FX Tour	FX AD- VANCED	DIRECT 8 BIT	DIRECT 16 BIT	XY
TOUR FOREGROUND GREEN	-	-	-	-	35	-	12	25	-	-	-
TOUR FOREGROUND BLUE	-	-	-	-	36	-	13	26	-	-	-
TOUR FOREGROUND WARM WHITE	-	-	-	-	37	-	14	27	-	-	-
TOUR BACKGROUND INTENSITY	-	-	-	-	38	-	15	28	-	-	-
TOUR BACKGROUND STROBE	-	-	-	-	39	-	16	29	-	-	-
TOUR BACKGROUND RED	-	-	-	-	40	-	17	30	-	-	-
TOUR BACKGROUND GREEN	-	-	-	-	41	-	18	31	-	-	-
TOUR BACKGROUND BLUE	-	-	-	-	42	-	19	32	-	-	-
TOUR BACKGROUND WARM WHITE	-	-	-	-	43	-	20	33	-	-	-

**PIXEL ENGINE DMX CHARTS (LUMIPIXB050)**

**PIXEL LAYOUT**

NOTE: PIXEL Engine is available only when used with DMX Modes including "Crossfade for Pixel Engine" channel: Basic, Standard, Extended.



**PIXEL**

**MODE**

PARAMETER	MODE		
	OFF	9PX	EXTENDED
RED 1	-	1	1
GREEN 1	-	2	2
BLUE 1	-	3	3
WARM WHITE 1	-	4	4
CROSSFADE PIXEL 1	-	-	5
CCT PIXEL 1	-	-	6
TINT PIXEL 1	-	-	7
...	...	...	...
RED 9	-	33	57
GREEN 9	-	34	58
BLUE 9	-	35	59
WARM WHITE 9	-	36	60
CROSSFADE PIXEL 9	-	-	61
CCT PIXEL 9	-	-	62
TINT PIXEL 9	-	-	63

## PIXEL ENGINE DMX CHARTS (LUMIPIXXB100)

## PIXEL LAYOUT

NOTE: PIXEL Engine is available only when used with DMX Modes including "Crossfade for Pixel Engine" channel: Basic, Standard, Extended.

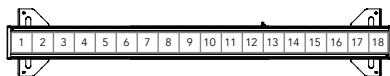

PARAMETER	PIXEL		
	OFF	MODE 18PX	EXTENDED
RED 1	-	1	1
GREEN 1	-	2	2
BLUE 1	-	3	3
WARM WHITE 1	-	4	4
CROSSFADE PIXEL 1	-	-	5
CCT PIXEL 1	-	-	6
TINT PIXEL 1	-	-	7
...	...	...	...
RED 18	-	69	120
GREEN 18	-	70	121
BLUE 18	-	71	122
WARM WHITE 18	-	72	123
CROSSFADE PIXEL 18	-	-	124
CCT PIXEL 18	-	-	125
TINT PIXEL 18	-	-	126

## CHANNEL DEFINITION

Dimmer					
Function	8 bit value		16 bit value		Note
	From	To	From	To	
Dimmer	0	255	0	65535	Default @ 0

Strobe					
Function	8 bit value		16 bit value		Note
	From	To	From	To	
Close	0	1	-	-	Default @ 255
Strobe from Slow to Fast	2	62	-	-	
Open	63	64	-	-	
Pulse In from slow to fast	65	125	-	-	
Open	126	127	-	-	
Pulse Out from slow to fast	128	188	-	-	
Open	189	190	-	-	
Random from slow to fast	191	251	-	-	
Open	252	255	-	-	

**Color 1**

Function	8 bit value		16 bit value		Note
	From	To	From	To	
RED in RGBW mode RED in RGB mode CYAN in CMY mode HUE in HSI mode	0	255	0	65535	Linear 0 - 100% Default @ 255 / 65535

**Color 2**

Function	8 bit value		16 bit value		Note
	From	To	From	To	
GREEN in RGBW mode GREEN in RGB mode MAGENTA in CMY mode SATURATION in HSI mode	0	255	0	65535	Linear 0 - 100% Default @ 255 / 65535

**Color 3**

Function	8 bit value		16 bit value		Note
	From	To	From	To	
BLUE in RGBW mode BLUE in RGB mode YELLOW in CMY mode INTENSITY in HSI mode	0	255	0	65535	Linear 0 - 100% Default @ 255 / 65535

**Color 4**

Function	8 bit value		16 bit value		Note
	From	To	From	To	
WHITE in RGBW mode RESERVED in RGB mode RESERVED in CMY mode RESERVED in HSI mode	0	255	0	65535	Linear 0 - 100% Default @ 255 / 65535

**X 1 - X 2**

Function	8 bit value		16 bit value		Note
	From	To	From	To	
0.0000 - 0.8500	0	255	0	65535	X1 used on Layer 1, X2 used on Layer 2

**Y 1 - Y 2**

Function	8 bit value		16 bit value		Note
	From	To	From	To	
0.0000 - 0.8500	0	255	0	65535	Y1 used on Layer 1, Y2 used on Layer 2



**CCT**

Function	CCT From	CCT To	8 bit value		16 bit value		Note
			From	To	From	To	
	2800	2900	0	4	0	910	Default @ 0
	2900	3000	4	7	910	1820	
	3000	3100	7	11	1820	2731	
	3100	3200	11	14	2731	3641	
	3200	3300	14	18	3641	4551	
	3300	3400	18	21	4551	5461	
	3400	3500	21	25	5461	6371	
	3500	3600	25	28	6371	7282	
	3600	3700	28	32	7282	8192	
	3700	3800	32	35	8192	9102	
	3800	3900	35	39	9102	10012	
	3900	4000	39	43	10012	10923	
	4000	4100	43	46	10923	11833	
	4100	4200	46	50	11833	12743	
	4200	4300	50	53	12743	13653	
	4300	4400	53	57	13653	14563	
	4400	4500	57	60	14563	15474	
	4500	4600	60	64	15474	16384	
	4600	4700	64	67	16384	17294	
	4700	4800	67	71	17294	18204	
	4800	4900	71	74	18204	19114	
	4900	5000	74	78	19114	20025	
	5000	5100	78	81	20025	20935	
	5100	5200	81	85	20935	21845	
	5200	5300	85	89	21845	22755	
	5300	5400	89	92	22755	23665	
	5400	5500	92	96	23665	24576	
	5500	5600	96	99	24576	25486	
	5600	5700	99	103	25486	26396	
	5700	5800	103	106	26396	27306	
	5800	5900	106	110	27306	28216	
	5900	6000	110	113	28216	29127	
	6000	6100	113	117	29127	30037	
	6100	6200	117	120	30037	30947	
	6200	6300	120	124	30947	31857	
	6300	6400	124	128	31857	32768	
	6400	6500	128	131	32768	33678	
	6500	6600	131	135	33678	34588	
	6600	6700	135	138	34588	35498	
	6700	6800	138	142	35498	36408	
	6800	6900	142	145	36408	37319	
	6900	7000	145	149	37319	38229	
	7000	7100	149	152	38229	39139	
	7100	7200	152	156	39139	40049	
	7200	7300	156	159	40049	40959	
	7300	7400	159	163	40959	41870	

**CCT**

Function	CCT From	CCT To	8 bit value		16 bit value		Note
			From	To	From	To	
	7400	7500	163	166	41870	42780	
	7500	7600	166	170	42780	43690	
	7600	7700	170	174	43690	44600	
	7700	7800	174	177	44600	45510	
	7800	7900	177	181	45510	46421	
	7900	8000	181	184	46421	47331	
	8000	8100	184	188	47331	48241	
	8100	8200	188	191	48241	49151	
	8200	8300	191	195	49151	50061	
	8300	8400	195	198	50061	50972	
	8400	8500	198	202	50972	51882	
	8500	8600	202	205	51882	52792	
	8600	8700	205	209	52792	53702	
	8700	8800	209	213	53702	54613	
	8800	8900	213	216	54613	55523	
	8900	9000	216	220	55523	56433	
	9000	9100	220	223	56433	57343	
	9100	9200	223	227	57343	58253	
	9200	9300	227	230	58253	59164	
	9300	9400	230	234	59164	60074	
	9400	9500	234	237	60074	60984	
	9500	9600	237	241	60984	61894	
	9600	9700	241	244	61894	62804	
	9700	9800	244	248	62804	63715	
	9800	9900	248	251	63715	64625	
	9900	10000	251	255	64625	65535	

**Tint**

Function	8 bit value		16 bit value		Note
	From	To	From	To	
-25% to 0	0	127	-	-	Default @ 128 Linear tint correction from -0.25 to +0.25
Neutral	128	128	-	-	
0 to 25%	129	255	-	-	

### Crossfade Hierarchy

Following order must be read from bottom to top. First Level is CCT, Second level is Color Mix, Third level is Pixel Engine (ETH1 in case of double Protocol used), Fourth level is Pixel Engine (ETH2)

ETH1 to ETH2	Fixture must be running a Pixel Engine using two protocols (Pixel Address -> Artnet+sAcn) Crossfade is inhibited in any other case.
Color to Pixel Engine	Fixture must be running a Pixel Engine. Pixel Engine is allocated on separated DMX Address. Crossfade is inhibited in any other case.
CCT to Color Mix	Crossfade running on Fixture Engine. Crossfades from CCT to Color Mix level. FXs and Tour FXs are running on Color Mix level.

#### Crossfade from ETH1 to ETH2

Function	8 bit value		16 bit value		Note
	From	To	From	To	
Linear Crossfade	0	255	0	65535	Default @ 0 Crossfade from Pixel Engine running on first ETH protocol to second Pixel Engine running on second ETH protocol

#### Crossfade from Color to Pixel Engine

Function	8 bit value		16 bit value		Note
	From	To	From	To	
Linear Crossfade	0	255	0	65535	Default @ 0 Crossfade from Color Layer to Pixel Engine

#### Crossfade from X/Y Layer 1 to X/Y Layer 2

Function	8 bit value		16 bit value		Note
	From	To	From	To	
Linear Crossfade	0	255	0	65535	Default @ 0 Crossfade from X/Y Layer 1 to X/Y Layer2

#### CTO on Colors

Function	8 bit value		16 bit value		Note
	From	To	From	To	
Linear CTO 0 - 100%	0	255	0	65535	Default @ 0

**Color Macro Brand**

Function	8 bit value		16 bit value		Note
	From	To	From	To	
No Function	0	0	-	-	Default @ 0
LEE Gels	1	50	-	-	
Color Gels	51	100	-	-	
RESERVED	101	255	-	-	

**Color Macro Category (when Color Macro Brand @ LEE Gels)**

Function	8 bit value		16 bit value		Note
	From	To	From	To	
Color Correction	0	50	-	-	Default @ 0
Color Filters	51	100	-	-	
600 Series	101	150	-	-	
Cosmetic Filters	151	200	-	-	
700 Series	201	255	-	-	

**Color Macro Category (when Color Macro Brand @ Color Gels)**

Function	8 bit value		16 bit value		Note
	From	To	From	To	
Color Correction	0	50	-	-	Default @ 0
CColor	51	100	-	-	
SSelection	101	150	-	-	
Lux	151	200	-	-	
Reserved	201	255	-	-	

**Gel (when Gel Category @ LEE: Color Correction)**

Function	8 bit value		16 bit value		Gel Number
	From	To	From	To	
Full CTB	0	1	-	-	3202
3/4 CTB	2	3	-	-	3203
1/2 CTB	4	5	-	-	3204
1/3 CTB	6	7	-	-	3206
1/4 CTB	8	9	-	-	3208
1/8 CTB	10	11	-	-	3216
Double CTB	12	13	-	-	3220
Full CTO	14	15	-	-	3407
3/4 CTO	16	17	-	-	3411
1/2 CTO	18	19	-	-	3408
1/4 CTO	20	21	-	-	3409
1/8 CTO	22	23	-	-	3410
Double CTO	24	25	-	-	3420
Full CTS	26	27	-	-	3441
1/2 CTS	28	29	-	-	3442
1/4 CTS	30	31	-	-	3443
1/8 CTS	32	33	-	-	3444
Full Plusgreen	34	35	-	-	3304
1/2 Plusgreen	36	37	-	-	3315
1/4 Plusgreen	38	39	-	-	3316
1/8 Plusgreen	40	41	-	-	3317
Full Minusgreen	42	43	-	-	3308
3/4 Minusgreen	44	45	-	-	3309
1/2 Minusgreen	46	47	-	-	3313
1/4 Minusgreen	48	49	-	-	3314
1/8 Minusgreen	50	51	-	-	3318
Fluorofilter	52	53	-	-	3310
Industrial Vapor	54	55	-	-	3150
Urban Vapor	56	57	-	-	3152
Tough Y-1	58	59	-	-	3107
Tough MT 54	60	61	-	-	3134
Tough MTY	62	63	-	-	3106
Tough MT2	64	65	-	-	3102
Reserved for Future Use	66	255	-	-	-

## Gel (when Gel Category @ Color: C.Color)

Function	8 bit value		16 bit value		Gel Number
	From	To	From	To	
15 Blue	0	1	-	-	4215
30 Blue	2	3	-	-	4230
60 Blue	4	5	-	-	4260
90 Blue	6	7	-	-	4290
7 Cyan	8	9	-	-	4307
15 Cyan	10	11	-	-	4315
30 Cyan	12	13	-	-	4330
60 Cyan	14	15	-	-	4360
90 Cyan	16	17	-	-	4390
15 Green	18	19	-	-	4415
30 Green	20	21	-	-	4430
60 Green	22	23	-	-	4460
90 Green	24	25	-	-	4490
15 Yellow	26	27	-	-	4515
30 Yellow	28	29	-	-	4530
60 Yellow	30	31	-	-	4560
90 Yellow	32	33	-	-	4590
15 Red	34	35	-	-	4615
30 Red	36	37	-	-	4630
60 Red	38	39	-	-	4660
90 Red	40	41	-	-	4690
15 Magenta	42	43	-	-	4715
30 Magenta	44	45	-	-	4730
60 Magenta	46	47	-	-	4760
90 Magenta	48	49	-	-	4790
15 Pink	50	51	-	-	4815
30 Pink	52	53	-	-	4830
60 Pink	54	55	-	-	4860
90 Pink	56	57	-	-	4890
15 Lavender	58	59	-	-	4915
30 Lavender	60	61	-	-	4930
60 Lavender	62	63	-	-	4960
90 Lavender	64	65	-	-	4990
Reserved for Future Use	66	255	-	-	-

**Gel (when Gel Category @ Color: C.Color)**

Function	8 bit value		16 bit value		Gel Number
	From	To	From	To	
VS Red	0	1	-	-	2001
VS Orange	2	3	-	-	2202
VS Yellow	4	5	-	-	2003
VS Green	6	7	-	-	2004
VS Cyan	8	9	-	-	2005
VS Azure	10	11	-	-	2006
VS Blue	12	13	-	-	2007
VS Indigo	14	15	-	-	2008
VS Violet	16	17	-	-	2009
VS Magenta	18	19	-	-	2010
Reserved for Future Use	20	255	-	-	-

## Gel (when Gel Category @ Color: C.Color)

Function	8 bit value		16 bit value		Gel Number
	From	To	From	To	
Bastard Amber	0	1	-	-	2
Pale Bastard Amber	2	3	-	-	302
No Color Straw	4	5	-	-	6
Pale Gold	6	7	-	-	8
Daffodil	8	9	-	-	310
Straw	10	11	-	-	12
Light Amber	12	13	-	-	16
Gallo Gold	14	15	-	-	316
Light Flame	16	17	-	-	17
Flame	18	19	-	-	18
Mayan Sun	20	21	-	-	318
Golden Amber	22	23	-	-	21
Soft Golden Amber	24	25	-	-	321
Orange	26	27	-	-	23
Henny Sky	28	29	-	-	325
Light Red	30	31	-	-	26
No Color Pink	32	33	-	-	33
Blush Pink	34	35	-	-	333
Flesh Pink	36	37	-	-	34
Pale Rose Pink	38	39	-	-	37
Salmon	40	41	-	-	41
Deep Salmon	42	43	-	-	42
Middle Rose	44	45	-	-	44
Light Rose Purple	46	47	-	-	47
Surprise Pink	48	49	-	-	51
No Color Blue	50	51	-	-	60
Clearwater	52	53	-	-	360
Booster Blue	54	55	-	-	62
Tipton Blue	56	57	-	-	362
Blue Bell	58	59	-	-	364
Daylight Blue	60	61	-	-	65
Tharon Delft Blue	62	63	-	-	365
Cerulean Blue	64	65	-	-	375
Bermuda Blue	66	67	-	-	376
Green Blue	68	69	-	-	77
Alice Blue	70	71	-	-	378
Primary Blue	72	73	-	-	80
Baldassari Blue	74	75	-	-	381
Medium Blue	76	77	-	-	83
Pale Yellow Green	78	79	-	-	87
Light Green	80	81	-	-	88
Moss Green	82	83	-	-	89
Primary Green	84	85	-	-	91
Turquoise	86	87	-	-	92
Blue Green	88	89	-	-	93
Chocolate	90	91	-	-	99
Reserved for Future Use	92	255	-	-	-



**Gel (when Gel Category @ LEE: Color Correction)**

Function	8 bit value		16 bit value		Gel Number
	From	To	From	To	
Double CTB	0	1	-	-	200
Full CTB	2	3	-	-	201
3/4 CTB	4	5	-	-	281
1/2 CTB	6	7	-	-	202
1/4 CTB	8	9	-	-	203
1/8 CTB	10	11	-	-	218
Double CTO	12	13	-	-	287
Full CTO	14	15	-	-	204
3/4 CTO	16	17	-	-	285
1/2 CTO	18	19	-	-	205
1/4 CTO	20	21	-	-	206
1/8 CTO	22	23	-	-	223
1 1/2 CTB	24	25	-	-	283
1 1/2 CTO	26	27	-	-	286
Full CTS	28	29	-	-	441
1/2 CTS	30	31	-	-	442
1/4 CTS	32	33	-	-	443
1/8 CTS	34	35	-	-	444
Full CTO + .3 ND	36	37	-	-	207
Full CTO + .6 ND	38	39	-	-	208
L.C.T. Yellow (Y1)	40	41	-	-	212
White Flame Green	42	43	-	-	213
LEE Fluorescent Green	44	45	-	-	219
Super Correction L.C.T. Yellow	46	47	-	-	230
Super Correction W.F. Green	48	49	-	-	232
H.M.I. (to Tungsten)	50	51	-	-	236
C.I.D. (to Tungsten)	52	53	-	-	237
C.S.I. (to Tungsten)	54	55	-	-	238
LEE Fluorescent 5700 Kelvin	56	57	-	-	241
LEE Fluorescent 4300 Kelvin	58	59	-	-	242
LEE Fluorescent 3600 Kelvin	60	61	-	-	243
LEE Plus Green	62	63	-	-	244
1/2 Plus Green	64	65	-	-	245
1/4 Plus Green	66	67	-	-	246
1/8 Plus Green	68	69	-	-	278
Lee Minus Green	70	71	-	-	247
1/2 Minus Green	72	73	-	-	248
1/4 Minus Green	74	75	-	-	249
1/8 Minus Green	76	77	-	-	279
Reserved for future Use	78	255	-	-	

**Gel (when Gel Category @ LEE: Color Filters)**

Function	8 bit value		16 bit value		Gel Number
	From	To	From	To	
Rose Pink	0	1	-	-	2
Lavender Tint	2	3	-	-	3
Medium Bastard Amber	4	5	-	-	4
Pale Yellow	6	7	-	-	7
Dark Salmon	8	9	-	-	8
Pale Amber Gold	10	11	-	-	9
Medium Yellow	12	13	-	-	10
Straw Tint	14	15	-	-	13
Surprise Peach	16	17	-	-	17
Fire	18	19	-	-	19
Medium Amber	20	21	-	-	20
Gold Amber	22	23	-	-	21
Dark Amber	24	25	-	-	22
Scarlet	26	27	-	-	24
Sunset Red	28	29	-	-	25
Bright Red	30	31	-	-	26
Light Pink	32	33	-	-	35
Medium Pink	34	35	-	-	36
Dark Magenta	36	37	-	-	46
Rose Purple	38	39	-	-	48
Light Lavender	40	41	-	-	52
Paler Lavender	42	43	-	-	53
Lavender	44	45	-	-	58
Mist Blue	46	47	-	-	61
Pale Blue	48	49	-	-	63
Sky Blue	50	51	-	-	68
Evening Blue	52	53	-	-	75
Just Blue	54	55	-	-	79
Deeper Blue	56	57	-	-	85
Lime Green	58	59	-	-	88
Moss Green	60	61	-	-	89
Dark Yellow Green	62	63	-	-	90
Spring Yellow	64	65	-	-	100
Yellow	66	67	-	-	101
Light Amber	68	69	-	-	102
Straw	70	71	-	-	103
Deep Amber	72	73	-	-	104
Primary Red	74	75	-	-	106
Light Rose	76	77	-	-	107
English Rose	78	79	-	-	108
Light Salmon	80	81	-	-	109
Middle Rose	82	83	-	-	110
Dark Pink	84	85	-	-	111
Magenta	86	87	-	-	113
Peacock Blue	88	89	-	-	115
Steel Blue	90	91	-	-	117

**Gel (when Gel Category @ LEE: Color Filters)**

Function	8 bit value		16 bit value		Gel Number
	From	To	From	To	
Light Blue	92	93	-	-	118
Deep Blue	94	95	-	-	120
LEE Green	96	97	-	-	121
Fern Green	98	99	-	-	122
Dark Green	100	101	-	-	124
Smokey Pink	102	103	-	-	127
Bright Pink	104	105	-	-	128
Marine Blue	106	107	-	-	131
Golden Amber	108	109	-	-	134
Deep Golden Amber	110	111	-	-	135
Pale Lavender	112	113	-	-	136
Special Lavender	114	115	-	-	137
Pale Green	116	117	-	-	138
Summer Blue	118	119	-	-	140
Pale Violet	120	121	-	-	142
Pale Navy Blue	122	123	-	-	143
No Color Blue	124	125	-	-	144
Apricot	126	127	-	-	147
Bright Rose	128	129	-	-	148
Gold Tint	130	131	-	-	151
Pale Gold	132	133	-	-	152
Pale Salmon	134	135	-	-	153
Pale Rose	136	137	-	-	154
Chocolate	138	139	-	-	156
Pink	140	141	-	-	157
No Color Straw	142	143	-	-	159
Slate Blue	144	145	-	-	161
Bastard Amber	146	147	-	-	162
Flame Red	148	149	-	-	164
Daylight Blue	150	151	-	-	165
Lilac Tint	152	153	-	-	169
Deep Lavender	154	155	-	-	170
Dark Steel Blue	156	157	-	-	174
Loving Amber	158	159	-	-	176
Dark Lavender	160	161	-	-	180
Light Red	162	163	-	-	182
Flesh Pink	164	165	-	-	192
Surprise Pink	166	167	-	-	194
Zenith Blue	168	169	-	-	195
True Blue	170	171	-	-	196
Alice Blue	172	173	-	-	197
Palace Blue	174	175	-	-	198
Regal Blue	176	177	-	-	199
Reserved for future Use	178	255	-	-	

**Gel (when Gel Category @ LEE: 600 series)**

Function	8 bit value		16 bit value		Gel Number
	From	To	From	To	
Arctic White	0	1	-	-	600
Silver	2	3	-	-	601
Platinum	4	5	-	-	602
Moonlight White	6	7	-	-	603
Full CT 85	8	9	-	-	604
Industry Sodium	10	11	-	-	650
HI Sodium	12	13	-	-	651
Urban Sodium	14	15	-	-	652
LO Sodium	16	17	-	-	653
Reserved	18	255	-	-	-

**Gel (when Gel Category @ LEE: Cosmetic Series)**

Function	8 bit value		16 bit value		Gel Number
	From	To	From	To	
Cosmetic Peach	0	1	-	-	184
Cosmetic Silver Rose	2	3	-	-	186
Cosmetic Rouge	4	5	-	-	187
Cosmetic Highlight	6	7	-	-	188
Cosmetic Silver Moss	8	9	-	-	189
Cosmetic Aqua Blue	10	11	-	-	191
Lily Frost	12	13	-	-	705
Shanklin Frost	14	15	-	-	717
Half Shanklin Frost	16	17	-	-	718
Durham Daylight Frost	18	19	-	-	720
Hampshire Rose	20	21	-	-	749
Durham Frost	22	23	-	-	750
Soft Amber Key 1	24	25	-	-	774
Soft Amber Key 2	26	27	-	-	775
Moroccan Frost	28	29	-	-	791
Blue Diffusion	30	31	-	-	217
Blue Frost	32	33	-	-	221
Daylight Blue Frost	34	35	-	-	224
Reserved for Future Use	36	255	-	-	-

**Gel (when Gel Category @ LEE: Color Filters)**

Function	8 bit value		16 bit value		Gel Number
	From	To	From	To	
Perfect Lavender	0	1	-	-	700
Provence	2	3	-	-	701
Special Pale Lavender	4	5	-	-	702
Cold Lavender	6	7	-	-	703
Lily	8	9	-	-	704
King Fals Lavender	10	11	-	-	706
Cool Lavender	12	13	-	-	708
Electric Lilac	14	15	-	-	709
Spir Special Blue	16	17	-	-	710
Cold Blue	18	19	-	-	711
Bedford Blue	20	21	-	-	712
Elysian Blue	22	23	-	-	714
Cabana Blue	24	25	-	-	715
Mikkel Blue	26	27	-	-	716
Colour Wash Blue	28	29	-	-	719
Berry Blue	30	31	-	-	721
Virgin Blue	32	33	-	-	723
Ocean Blue	34	35	-	-	724
Old Steel Blue	36	37	-	-	725
Steel Green	38	39	-	-	728
Liberty Green	40	41	-	-	730
Dirty Ice	42	43	-	-	731
Damp Squib	44	45	-	-	733
JAS Green	46	47	-	-	738
Bram Brown	48	49	-	-	742
Dirty White	50	51	-	-	744
Brown	52	53	-	-	746
Easy White	54	55	-	-	747
Seedy Pink	56	57	-	-	748
Wheat	58	59	-	-	763
Sun Colour Straw	60	61	-	-	764
LEE Yellow	62	63	-	-	765
Cardbox Amber	64	65	-	-	773
Nectarine	66	67	-	-	776
Millenium Gold	68	69	-	-	778
Bastard Pink	70	71	-	-	779
Terry Red	72	73	-	-	781
Blood Red	74	75	-	-	789
Moroccan Pink	76	77	-	-	790
Pretty n'Pink	78	79	-	-	794
Magical Magenta	80	81	-	-	795
Reserved for Future Use	82	255	-	-	-

**Source Emulation Category Selector**

Function	8 bit value		16 bit value		Note
	From	To	From	To	
No Function	0	0	-	-	Default @ 0
Incandescent	1	50	-	-	
Fluorescent	51	100	-	-	
Discharge	101	150	-	-	
Other	151	200	-	-	
Reserved	201	255	-	-	

**Source Emulation Macro (when Source Emulation Category @ Incandescent)**

Function	8 bit value		16 bit value		Note
	From	To	From	To	
Tungsten Bulb	0	1	-	-	Default @ 0
Incandescent	2	3	-	-	
Halogen	4	5	-	-	
Antique Bulb	6	7	-	-	
Warm Antique Bulb	8	9	-	-	
Christmas Light	10	11	-	-	
Night Light	12	13	-	-	
Infrared Heat Lamp	14	15	-	-	
Grow Light	16	17	-	-	
Reserved	18	255	-	-	

**Source Emulation Macro (when Source Emulation Category @ Fluorescent)**

Function	8 bit value		16 bit value		Note
	From	To	From	To	
Tungsten Bulb	0	1	-	-	Default @ 0
Incandescent	2	3	-	-	
Halogen	4	5	-	-	
Antique Bulb	6	7	-	-	
Warm Antique Bulb	8	9	-	-	
Christmas Light	10	11	-	-	
Night Light	12	13	-	-	
Infrared Heat Lamp	14	15	-	-	
Grow Light	16	17	-	-	
Reserved	18	255	-	-	

**Source Emulation Macro (when Source Emulation Category @ Discharge)**

Function	8 bit value		16 bit value		Note
	From	To	From	To	
HMI	0	1	-	-	Default @ 0
High Pressure Sodium	2	3	-	-	
Low Pressure Sodium	4	5	-	-	
Mercury Vapor	6	7	-	-	
Metal Halide	8	9	-	-	
Ceramic	10	11	-	-	
Carbon Arc	12	13	-	-	
Xenon	14	15	-	-	
Reserved	16	255	-	-	

**Source Emulation Macro (when Source Emulation Category @ Other)**

Function	8 bit value		16 bit value		Note
	From	To	From	To	
Candle	0	1	-	-	Default @ 0
Gas Fire	2	3	-	-	
Sun Direct	4	5	-	-	
Sun Overcast	6	7	-	-	
Sun Blue Hour	8	9	-	-	
Mobile Phone	10	11	-	-	
Computer Monitor	12	13	-	-	
Electroluminescence	14	15	-	-	
Blow Torch	16	17	-	-	
Road Flare	18	19	-	-	
Amber Caution	20	21	-	-	
Green Traffic Light	22	23	-	-	
Yellow Traffic Light	24	25	-	-	
Red Traffic Light	26	27	-	-	
Blue Glow Stick	28	29	-	-	
Green Glow Stick	30	31	-	-	
Red Glow Stick	32	33	-	-	
Yellow Glow Stick	34	35	-	-	
Pink Glow Stick	36	37	-	-	
Violet Glow Stick	38	39	-	-	
Reserved	40	255	-	-	

**Control Mode Selector**

Function	8 bit value		16 bit value		Note
	From	To	From	To	
Cinema FX	0	12	-	-	Default @ 0
Source Emulation	13	24	-	-	
CCT	25	36	-	-	
HSI	37	48	-	-	
Fixed Colors	49	60	-	-	
White Presets	61	72	-	-	
Color Macro	73	84	-	-	
Manual Colors	85	96	-	-	
XY	97	108	-	-	
User Preset	109	120	-	-	
Reserved	121	255	-	-	

### Control Mode Selector

Following table is defining usage of Parameter Channels.  
Blank cells means that channel is Reserved / Not being used.

Mode Selected	Cinema FX	Source Emulation	CCT	HSI	Fixed Colors	White Presets	Color Macro	Manual Colors	XY	User Preset
Cinema FX Selector	FX Selector	NOT USED	NOT USED	NOT USED	NOT USED	NOT USED	NOT USED	NOT USED	NOT USED	NOT USED
Parameter 1	FX Parameter 1	Source Emulation Category Selector	CCT	Hue	Color Macros	White Presets	COLOR MACRO BRAND	RED	X	PRESET
Parameter 2	FX Parameter 2	Source Emulation Macro Selector	TINT	Saturation	CTO on Colors	Tint	COLOR MACRO CATEGORY	GREEN	Y	
Parameter 3	FX Parameter 3						COLOR MACRO	BLUE		
Parameter 4	FX Parameter 4							WHITE		
Parameter 5	FX Parameter 5									
Parameter 6	FX Parameter 6									
Parameter 7	FX Parameter 7									

### Cinema FX Selector

Function	8 bit value		16 bit value		Note
	From	To	From	To	
No Function	0	1	-	-	Default @ 0
Party Effect	2	3	-	-	
Candle	4	5	-	-	
Clouds Passing	6	7	-	-	
Club Lights	8	9	-	-	
Color Chase	10	11	-	-	
Cop Car	12	13	-	-	
Fire	14	15	-	-	
Fireworks	16	17	-	-	
Strobe	18	19	-	-	
Lightning	20	21	-	-	
Paparazzi	22	23	-	-	
Pulsing	24	25	-	-	
Television	26	27	-	-	
Explosion	28	29	-	-	
Fluorescent Flicker	30	31	-	-	
Process Effect	32	33	-	-	
Welding	34	35	-	-	
Reserved for Future Use	36	255	-	-	



**CCT (Used via Extended Mode @ 2200K - 15000K)**

Function	CCT From	CCT To	8 bit value		16 bit value		Note
			From	To	From	To	
	2200	2300	0	2	0	512	Default @ 0
	2300	2400	2	4	512	1024	
	2400	2500	4	6	1024	1536	
	2500	2600	6	8	1536	2048	
	2600	2700	8	10	2048	2560	
	2700	2800	10	12	2560	3072	
	2800	2900	12	14	3072	3584	
	2900	3000	14	16	3584	4096	
	3000	3100	16	18	4096	4608	
	3100	3200	18	20	4608	5120	
	3200	3300	20	22	5120	5632	
	3300	3400	22	24	5632	6144	
	3400	3500	24	26	6144	6656	
	3500	3600	26	28	6656	7168	
	3600	3700	28	30	7168	7680	
	3700	3800	30	32	7680	8192	
	3800	3900	32	34	8192	8704	
	3900	4000	34	36	8704	9216	
	4000	4100	36	38	9216	9728	
	4100	4200	38	40	9728	10240	
	4200	4300	40	42	10240	10752	
	4300	4400	42	44	10752	11264	
	4400	4500	44	46	11264	11776	
	4500	4600	46	48	11776	12288	
	4600	4700	48	50	12288	12800	
	4700	4800	50	52	12800	13312	
	4800	4900	52	54	13312	13824	
	4900	5000	54	56	13824	14336	
	5000	5100	56	58	14336	14848	
	5100	5200	58	60	14848	15360	
	5200	5300	60	62	15360	15872	
	5300	5400	62	64	15872	16384	
	5400	5500	64	66	16384	16896	
	5500	5600	66	68	16896	17408	
	5600	5700	68	70	17408	17920	
	5700	5800	70	72	17920	18432	
	5800	5900	72	74	18432	18944	
	5900	6000	74	76	18944	19456	
	6000	6100	76	78	19456	19968	
	6100	6200	78	80	19968	20480	
	6200	6300	80	82	20480	20992	
	6300	6400	82	84	20992	21504	
	6400	6500	84	86	21504	22016	
	6500	6600	86	88	22016	22528	
	6600	6700	88	90	22528	23040	
	6700	6800	90	92	23040	23552	

**CCT (Used via Extended Mode @ 2200K - 15000K)**

Function		8 bit value		16 bit value		Note
CCT From	CCT To	From	To	From	To	
6800	6900	92	94	23552	24064	
6900	7000	94	96	24064	24576	
7000	7100	96	98	24576	25088	
7100	7200	98	100	25088	25600	
7200	7300	100	102	25600	26112	
7300	7400	102	104	26112	26624	
7400	7500	104	106	26624	27136	
7500	7600	106	108	27136	27648	
7600	7700	108	110	27648	28160	
7700	7800	110	112	28160	28672	
7800	7900	112	114	28672	29184	
7900	8000	114	116	29184	29696	
8000	8100	116	118	29696	30208	
8100	8200	118	120	30208	30720	
8200	8300	120	122	30720	31232	
8300	8400	122	124	31232	31744	
8400	8500	124	126	31744	32256	
8500	8600	126	128	32256	32768	
8600	8700	128	129	32768	33279	
8700	8800	129	131	33279	33791	
8800	8900	131	133	33791	34303	
8900	9000	133	135	34303	34815	
9000	9100	135	137	34815	35327	
9100	9200	137	139	35327	35839	
9200	9300	139	141	35839	36351	
9300	9400	141	143	36351	36863	
9400	9500	143	145	36863	37375	
9500	9600	145	147	37375	37887	
9600	9700	147	149	37887	38399	
9700	9800	149	151	38399	38911	
9800	9900	151	153	38911	39423	
9900	10000	153	155	39423	39935	
10000	10100	155	157	39935	40447	
10100	10200	157	159	40447	40959	
10200	10300	159	161	40959	41471	
10300	10400	161	163	41471	41983	
10400	10500	163	165	41983	42495	
10500	10600	165	167	42495	43007	
10600	10700	167	169	43007	43519	
10700	10800	169	171	43519	44031	
10800	10900	171	173	44031	44543	
10900	11000	173	175	44543	45055	
11000	11100	175	177	45055	45567	
11100	11200	177	179	45567	46079	
11200	11300	179	181	46079	46591	
11300	11400	181	183	46591	47103	

**CCT (Used via Extended Mode @ 2200K - 15000K)**

Function		8 bit value		16 bit value		Note
CCT From	CCT To	From	To	From	To	
11400	11500	183	185	47103	47615	
11500	11600	185	187	47615	48127	
11600	11700	187	189	48127	48639	
11700	11800	189	191	48639	49151	
11800	11900	191	193	49151	49663	
11900	12000	193	195	49663	50175	
12000	12100	195	197	50175	50687	
12100	12200	197	199	50687	51199	
12200	12300	199	201	51199	51711	
12300	12400	201	203	51711	52223	
12400	12500	203	205	52223	52735	
12500	12600	205	207	52735	53247	
12600	12700	207	209	53247	53759	
12700	12800	209	211	53759	54271	
12800	12900	211	213	54271	54783	
12900	13000	213	215	54783	55295	
13000	13100	215	217	55295	55807	
13100	13200	217	219	55807	56319	
13200	13300	219	221	56319	56831	
13300	13400	221	223	56831	57343	
13400	13500	223	225	57343	57855	
13500	13600	225	227	57855	58367	
13600	13700	227	229	58367	58879	
13700	13800	229	231	58879	59391	
13800	13900	231	233	59391	59903	
13900	14000	233	235	59903	60415	
14000	14100	235	237	60415	60927	
14100	14200	237	239	60927	61439	
14200	14300	239	241	61439	61951	
14300	14400	241	243	61951	62463	
14400	14500	243	245	62463	62975	
14500	14600	245	247	62975	63487	
14600	14700	247	249	63487	63999	
14700	14800	249	251	63999	64511	
14800	14900	251	253	64511	65023	
14900	15000	253	255	65023	65535	

**Fixed Color - Macro**

Function	8 bit value		16 bit value		Note
	From	To	From	To	
R	0	1	-	-	Default @ 0
G	2	3	-	-	
B	4	5	-	-	
W	6	7	-	-	
GB	8	9	-	-	
RB	10	11	-	-	
RG	12	13	-	-	
RGB	14	15	-	-	
RW	16	17	-	-	
GW	18	19	-	-	
BW	20	21	-	-	
RGW	22	23	-	-	
RBW	24	25	-	-	
GBW	26	27	-	-	
RGBW	28	29	-	-	
Reserved for Future Use	30	255	-	-	

**White Presets - White Presets**

Function	8 bit value		16 bit value		Note
	From	To	From	To	
2800K	0	1	-	-	Default @ 0
3200K	2	3	-	-	
3500K	4	5	-	-	
4000K	6	7	-	-	
4500K	8	9	-	-	
5000K	10	11	-	-	
5600K	12	13	-	-	
6000K	14	15	-	-	
6500K	16	17	-	-	
7000K	18	19	-	-	
7500K	20	21	-	-	
8000K	22	23	-	-	
8500K	24	25	-	-	
9000K	26	27	-	-	
9500K	28	29	-	-	
10000K	30	31	-	-	
Reserved for Future Use	32	255	-	-	

**White Presets - White Presets**

Function	8 bit value		16 bit value		Note
	From	To	From	To	
Preset 1	0	1	-	-	Default @ 0
Preset 2	2	3	-	-	
Preset 3	4	5	-	-	
Preset 4	6	7	-	-	
Preset 5	8	9	-	-	
Preset 6	10	11	-	-	
Preset 7	12	13	-	-	
Preset 8	14	15	-	-	
Preset 9	16	17	-	-	
Preset 10	18	19	-	-	
Reserved for Future Use	20	255	-	-	

**Tour FX Selector**

Function	8 bit value		16 bit value		Note
	From	To	From	To	
No FX	0	25	-	-	Default @ 0
FX 1	26	35	-	-	
FX 2	36	45	-	-	
FX 3	46	55	-	-	
FX 4	56	65	-	-	
FX 5	66	75	-	-	
FX 6	76	85	-	-	
FX 7	86	95	-	-	
FX 8	96	105	-	-	
FX 9	106	115	-	-	
FX 10	116	125	-	-	
FX 11	126	135	-	-	
FX 12	136	145	-	-	
FX 13	146	155	-	-	
FX 14	156	165	-	-	
FX 15	166	175	-	-	
FX 16	176	185	-	-	
FX 17	186	195	-	-	
FX 18	196	205	-	-	
FX 19	206	215	-	-	
FX 20	216	225	-	-	
FX 21	226	235	-	-	
FX 22	236	245	-	-	
FX 23	246	255	-	-	

**Tour Pattern Speed**

Function	8 bit value		16 bit value		Note
	From	To	From	To	
Indexing	0	127	-	-	Default @ 0
CW from fast to slow	128	190	-	-	
Stop	191	192	-	-	
CCW from slow to fast	193	255	-	-	

### Tour Pattern Fade

Function	8 bit value		16 bit value		Note
	From	To	From	To	
0% - 100%	0	255	-	-	Default @ 0

### Tour Pattern Transition

Function	8 bit value		16 bit value		Note
	From	To	From	To	
0% - 100%	0	255	-	-	Default @ 0

### Tour Foreground Intensity

Function	8 bit value		16 bit value		Note
	From	To	From	To	
0% - 100%	0	255	-	-	Default @ 0

### Tour Foreground Strobe

Function	8 bit value		16 bit value		Note
	From	To	From	To	
Close	0	1	-	-	Default @ 255
Strobe from Slow to Fast	2	62	-	-	
Open	63	64	-	-	
Pulse In from slow to fast	65	125	-	-	
Open	126	127	-	-	
Pulse Out from slow to fast	128	188	-	-	
Open	189	190	-	-	
Random from slow to fast	191	251	-	-	
Open	252	255	-	-	

### Tour Foreground Red

Function	8 bit value		16 bit value		Note
	From	To	From	To	
0 - 100%	0	255	0	65535	Linear 0 - 100% Default @ 255 / 65535

### Tour Foreground Green

Function	8 bit value		16 bit value		Note
	From	To	From	To	
0 - 100%	0	255	0	65535	Linear 0 - 100% Default @ 255 / 65535

**Tour Foreground Blue**

Function	8 bit value		16 bit value		Note
	From	To	From	To	
0 - 100%	0	255	0	65535	Linear 0 - 100% Default @ 255 / 65535

**Tour Foreground White**

Function	8 bit value		16 bit value		Note
	From	To	From	To	
0 - 100%	0	255	0	65535	Linear 0 - 100% Default @ 255 / 65535

**Tour Background Intensity**

Function	8 bit value		16 bit value		Note
	From	To	From	To	
0% - 100%	0	255	-	-	Default @ 0

**Tour Background Strobe**

Function	8 bit value		16 bit value		Note
	From	To	From	To	
Close	0	1	-	-	Default @ 255
Strobe from Slow to Fast	2	62	-	-	
Open	63	64	-	-	
Pulse In from slow to fast	65	125	-	-	
Open	126	127	-	-	
Pulse Out from slow to fast	128	188	-	-	
Open	189	190	-	-	
Random from slow to fast	191	251	-	-	
Open	252	255	-	-	

**Tour Background Red**

Function	8 bit value		16 bit value		Note
	From	To	From	To	
0 - 100%	0	255	0	65535	Linear 0 - 100% Default @ 255 / 65535

**Tour Background Green**

Function	8 bit value		16 bit value		Note
	From	To	From	To	
0 - 100%	0	255	0	65535	Linear 0 - 100% Default @ 255 / 65535

**Tour Background Blue**

Function	8 bit value		16 bit value		Note
	From	To	From	To	
0 - 100%	0	255	0	65535	Linear 0 - 100% Default @ 255 / 65535

**Tour Background White**

Function	8 bit value		16 bit value		Note
	From	To	From	To	
0 - 100%	0	255	0	65535	Linear 0 - 100% Default @ 255 / 65535

**Party Effect - P1: Saturation**

Function	8 bit value		16 bit value		Note
	From	To	From	To	
CCT 2800K - 10000K	0	0	0	255	Default @ 0
Saturation 0 - 1	1	255	256	65535	

**Party Effect - P2: Speed**

Function	8 bit value		16 bit value		Note
	From	To	From	To	
Slow to fast	0	255	0	65535	Default @ 0

**Candle - P1: CCT Range**

Function	8 bit value		16 bit value		Note
	From	To	From	To	
CCT 1400K - 1700K	0	84	0	21759	Default @ 0
CCT 1700K - 2000K	85	170	21760	43775	
CCT 2000K - 2300K	171	255	43776	65535	

**Candle - P2: Speed**

Function	8 bit value		16 bit value		Note
	From	To	From	To	
Slow to fast	0	255	0	65535	Default @ 0

**Clouds Passing - P1: Offset**

Function	8 bit value		16 bit value		Note
	From	To	From	To	
0 to 50	0	255	0	65535	Default @ 0

**Clouds Passing - P2: Speed**

Function	8 bit value		16 bit value		Note
	From	To	From	To	
Slow to fast	0	255	0	65535	Default @ 0



**Clouds Passing - P3: Trigger**

Function	8 bit value		16 bit value		Note
	From	To	From	To	
Reserved	0	254	0	65279	Default @ 0
Reset Loop	255	255	65280	65535	

**Club Lights - P1: Colors**

Function	8 bit value		16 bit value		Note
	From	To	From	To	
3 Colors	0	31	0	8191	Default @ 0
6 Colors	32	63	8192	16383	
9 Colors	64	95	16384	24575	
12 Colors	96	127	24576	32767	
15 Colors	128	159	32768	40959	
18 Colors	160	191	40960	49151	
21 Colors	192	223	49152	57343	
24 Colors	224	255	57344	65535	

**Club Lights - P2: Speed**

Function	8 bit value		16 bit value		Note
	From	To	From	To	
Slow to fast	0	255	0	65535	Default @ 0

**Color Chase - P3: Saturation**

Function	8 bit value		16 bit value		Note
	From	To	From	To	
CCT 2800K - 10000K	0	0	0	255	Default @ 0
Saturation 0 - 1	1	255	256	65535	

**Color Chase - P4: Trigger**

Function	8 bit value		16 bit value		Note
	From	To	From	To	
Reserved	0	254	0	65279	Default @ 0
Reset Loop	255	255	65280	65535	

**Cop Car - P1: Color Combinations**

Function	8 bit value		16 bit value		Note
	From	To	From	To	
Just Blue	0	27	0	7167	Default @ 0
Blue and Red	28	55	7168	14335	
Blue and White	56	83	14336	21503	
Blue, Red and White	84	111	21504	28671	
Blue and Amber	112	139	28672	35839	
Blue, Red and Amber	140	167	35840	43007	
Red and Amber	168	195	43008	50175	
Amber	196	223	50176	57343	
Red	224	255	57344	65535	

**Cop Car - P2: Flash Pattern**

Function	8 bit value		16 bit value		Note
	From	To	From	To	
Single Flash	0	31	0	8191	Default @ 0
Double Flash	32	63	8192	16383	
Quint All Flash	64	95	16384	24575	
Quint Flash	96	127	24576	32767	
Quad Flash	128	159	32768	40959	
Cycle All	160	191	40960	49151	
Reserved	192	255	49152	65535	

**Cop Car - P3: Speed**

Function	8 bit value		16 bit value		Note
	From	To	From	To	
Slow to fast	0	255	0	65535	Default @ 0

**Fire - P1: CCT Range**

Function	8 bit value		16 bit value		Note
	From	To	From	To	
CCT 1800K - 2200K	0	84	0	21759	Default @ 0
CCT 2200K - 2600K	85	170	21760	43775	
CCT 2600K - 3000K	171	255	43776	65535	

**Fire - P2: Speed**

Function	8 bit value		16 bit value		Note
	From	To	From	To	
Slow to fast	0	255	0	65535	Default @ 0

**Fireworks - P1: Color Combinations**

Function	8 bit value		16 bit value		Note
	From	To	From	To	
Colors	0	63	0	16128	Default @ 0
White	64	127	16129	32767	
Colors and White	128	191	32768	48896	
Reserved	192	255	48897	65535	

**Fireworks - P2: Speed**

Function	8 bit value		16 bit value		Note
	From	To	From	To	
Slow to fast	0	255	0	65535	Default @ 0

**Strobe - P1: Speed**

Function	8 bit value		16 bit value		Note
	From	To	From	To	
Slow to fast	0	255	0	65535	Default @ 0

**Strobe - P2: CCT**

Function	8 bit value		16 bit value		Note
	From	To	From	To	
CCT 2800K - 10000K	0	255	0	65535	Default @ 0

**Strobe - P3: Green Magenta Point**

Function	8 bit value		16 bit value		Note
	From	To	From	To	
Neutral / No Effect	0	1	0	511	Default @ 128
Full Minus Green	2	3	512	1023	
-99% to -1%	4	126	1024	32511	
Neutral / No Effect	127	128	32512	33023	
1% to 99%	129	251	33024	64511	
Full Plus Green	252	253	64512	65023	
Neutral / No Effect	254	255	65024	65535	

**Strobe - P4: Crossfade from CCT to Color**

Function	8 bit value		16 bit value		Note
	From	To	From	To	
Linear Crossfade	0	255	0	65535	Default @ 0

**Strobe - P5: Hue**

Function	8 bit value		16 bit value		Note
	From	To	From	To	
0 - 360°	0	255	0	65535	Default @ 0

**Strobe - P6: Saturation**

Function	8 bit value		16 bit value		Note
	From	To	From	To	
0 - 100%	0	255	0	65535	Default @ 0

**Lightning - P1: Frequency**

Function	8 bit value		16 bit value		Note
	From	To	From	To	
2 - 14 lightning strikes set	0	254	0	65279	Default @ 0
Random	255	255	65280	65535	

**Lightning - P2: Speed**

Function	8 bit value		16 bit value		Note
	From	To	From	To	
0 - 10 flashes / second	0	254	0	65279	Default @ 0
Random	255	255	65280	65535	

**Lightning - P3: CCT**

Function	8 bit value		16 bit value		Note
	From	To	From	To	
CCT 2800K - 10000K	0	255	0	65535	Default @ 0

### Lightning - P4: Green Magenta Point

Function	8 bit value		16 bit value		Note
	From	To	From	To	
Neutral / No Effect	0	1	0	511	Default @ 128
Full Minus Green	2	3	512	1023	
-99% to -1%	4	126	1024	32511	
Neutral / No Effect	127	128	32512	33023	
1% to 99%	129	251	33024	64511	
Full Plus Green	252	253	64512	65023	
Neutral / No Effect	254	255	65024	65535	

### Lightning - P5: Trigger

Function	8 bit value		16 bit value		Note
	From	To	From	To	
Reserved	0	254	0	65279	Default @ 0
Reset Loop	255	255	65280	65535	

### Paparazzi - P1: Frequency

Function	8 bit value		16 bit value		Note
	From	To	From	To	
6 to 120 Flashes / min	0	255	0	65535	Default @ 0

### Paparazzi - P2: Flash Type

Function	8 bit value		16 bit value		Note
	From	To	From	To	
Flash Bulb	0	127	0	32767	Default @ 0
Modern Flash	128	255	32768	65535	

### Paparazzi - P3: CCT

Function	8 bit value		16 bit value		Note
	From	To	From	To	
CCT 2800K - 10000K	0	255	0	65535	Default @ 0

### Paparazzi - P4: Green Magenta Point

Function	8 bit value		16 bit value		Note
	From	To	From	To	
Neutral / No Effect	0	1	0	511	Default @ 128
Full Minus Green	2	3	512	1023	
-99% to -1%	4	126	1024	32511	
Neutral / No Effect	127	128	32512	33023	
1% to 99%	129	251	33024	64511	
Full Plus Green	252	253	64512	65023	
Neutral / No Effect	254	255	65024	65535	

**Pulsing - P1: Frequency**

Function	8 bit value		16 bit value		Note
	From	To	From	To	
5 to 90 Pulses/minute	0	255	0	65535	Default @ 0

**Pulsing - P2: Pulse Duration**

Function	8 bit value		16 bit value		Note
	From	To	From	To	
4s to 0.25s	0	255	0	65535	Default @ 0

**Pulsing - P3: CCT**

Function	8 bit value		16 bit value		Note
	From	To	From	To	
CCT 2800K - 10000K	0	255	0	65535	Default @ 0

**Pulsing - P4: Green Magenta Point**

Function	8 bit value		16 bit value		Note
	From	To	From	To	
Neutral / No Effect	0	1	0	511	Default @ 128
Full Minus Green	2	3	512	1023	
-99% to -1%	4	126	1024	32511	
Neutral / No Effect	127	128	32512	33023	
1% to 99%	129	251	33024	64511	
Full Plus Green	252	253	64512	65023	
Neutral / No Effect	254	255	65024	65535	

**Pulsing - P5: Crossfade from CCT to Color**

Function	8 bit value		16 bit value		Note
	From	To	From	To	
Linear Crossfade	0	255	0	65535	Default @ 0

**Pulsing - P6: Hue**

Function	8 bit value		16 bit value		Note
	From	To	From	To	
0 - 360°	0	255	0	65535	Default @ 0

**Pulsing - P7: Saturation**

Function	8 bit value		16 bit value		Note
	From	To	From	To	
0 - 100%	0	255	0	65535	Default @ 0

**Television - P1: CCT Range**

Function	8 bit value		16 bit value		Note
	From	To	From	To	
CCT 2800K - 4700K	0	84	0	21759	Default @ 0
CCT 4700K - 6500K	85	170	21760	43775	
CCT 6500K - 10000K	171	255	43776	65535	

**Television - P2: Speed**

Function	8 bit value		16 bit value		Note
	From	To	From	To	
Slow to fast	0	255	0	65535	Default @ 0

**Explosion - P1: Frequency**

Function	8 bit value		16 bit value		Note
	From	To	From	To	
5 to 90 Pulses/minute	0	255	0	65535	Default @ 0

**Explosion - P2: Trigger**

Function	8 bit value		16 bit value		Note
	From	To	From	To	
Auto	0	250	0	64255	Default @ 0
Manual Explosion	251	255	64256	65535	

**Explosion - P3: CCT**

Function	8 bit value		16 bit value		Note
	From	To	From	To	
CCT 2800K - 10000K	0	255	0	65535	Default @ 0

**Explosion - P4: Green Magenta Point**

Function	8 bit value		16 bit value		Note
	From	To	From	To	
Neutral / No Effect	0	1	0	511	Default @ 128
Full Minus Green	2	3	512	1023	
-99% to -1%	4	126	1024	32511	
Neutral / No Effect	127	128	32512	33023	
1% to 99%	129	251	33024	64511	
Full Plus Green	252	253	64512	65023	
Neutral / No Effect	254	255	65024	65535	

**Explosion - P5: Crossfade from CCT to Color**

Function	8 bit value		16 bit value		Note
	From	To	From	To	
Linear Crossfade	0	255	0	65535	Default @ 0

### Explosion - P6: Hue

Function	8 bit value		16 bit value		Note
	From	To	From	To	
0 - 360°	0	255	0	65535	Default @ 0

### Explosion - P7: Saturation

Function	8 bit value		16 bit value		Note
	From	To	From	To	
0 - 100%	0	255	0	65535	Default @ 0

### Fluorescent Flicker - P1: Speed

Function	8 bit value		16 bit value		Note
	From	To	From	To	
Slow to fast	0	255	0	65535	Default @ 0

### Fluorescent Flicker - P2: Frequency

Function	8 bit value		16 bit value		Note
	From	To	From	To	
3 to 10 flickers per second	0	255	0	65535	Default @ 0

### Fluorescent Flicker - P3: CCT

Function	8 bit value		16 bit value		Note
	From	To	From	To	
CCT 2800K - 10000K	0	255	0	65535	Default @ 0

### Fluorescent Flicker - P4: Green Magenta Point

Function	8 bit value		16 bit value		Note
	From	To	From	To	
Neutral / No Effect	0	1	0	511	Default @ 128
Full Minus Green	2	3	512	1023	
-99% to -1%	4	126	1024	32511	
Neutral / No Effect	127	128	32512	33023	
1% to 99%	129	251	33024	64511	
Full Plus Green	252	253	64512	65023	
Neutral / No Effect	254	255	65024	65535	

### Fluorescent Flicker - P5: Crossfade from CCT to Color

Function	8 bit value		16 bit value		Note
	From	To	From	To	
Linear Crossfade	0	255	0	65535	Default @ 0

### Fluorescent Flicker - P6: Hue

Function	8 bit value		16 bit value		Note
	From	To	From	To	
0 - 360°	0	255	0	65535	Default @ 0

### Fluorescent Flicker - P7: Saturation

Function	8 bit value		16 bit value		Note
	From	To	From	To	
0 - 100%	0	255	0	65535	Default @ 0

**Process Effect - P1: Speed**

Function	8 bit value		16 bit value		Note
	From	To	From	To	
Slow to fast	0	255	0	65535	Default @ 0

**Process Effect - P2: Direction**

Function	8 bit value		16 bit value		Note
	From	To	From	To	
Left to Right	0	127	0	32767	Default @ 0
Right to Left	128	255	32768	65535	

**Process Effect - P3: CCT**

Function	8 bit value		16 bit value		Note
	From	To	From	To	
CCT 2800K - 10000K	0	255	0	65535	Default @ 0

**Process Effect - P4: Green Magenta Point**

Function	8 bit value		16 bit value		Note
	From	To	From	To	
Neutral / No Effect	0	1	0	511	Default @ 128
Full Minus Green	2	3	512	1023	
-99% to -1%	4	126	1024	32511	
Neutral / No Effect	127	128	32512	33023	
1% to 99%	129	251	33024	64511	
Full Plus Green	252	253	64512	65023	
Neutral / No Effect	254	255	65024	65535	

**Process Effect - P5: Crossfade from CCT to Color**

Function	8 bit value		16 bit value		Note
	From	To	From	To	
Linear Crossfade	0	255	0	65535	Default @ 0

**Process Effect - P6: Hue**

Function	8 bit value		16 bit value		Note
	From	To	From	To	
0 - 360°	0	255	0	65535	Default @ 0

**Process Effect - P7: Saturation**

Function	8 bit value		16 bit value		Note
	From	To	From	To	
0 - 100%	0	255	0	65535	Default @ 0



**Fluorescent Flicker - P1: Speed**

Function	8 bit value		16 bit value		Note
	From	To	From	To	
Slow to fast	0	255	0	65535	Default @ 0

**Welding - P2: Minimum Intensity**

Function	8 bit value		16 bit value		Note
	From	To	From	To	
0% to 75% minimum intensity level	0	255	0	65535	Default @ 0

**Welding - P3: CCT**

Function	8 bit value		16 bit value		Note
	From	To	From	To	
CCT 2800K - 10000K	0	255	0	65535	Default @ 0

**Welding - P4: Green Magenta Point**

Function	8 bit value		16 bit value		Note
	From	To	From	To	
Neutral / No Effect	0	1	0	511	Default @ 128
Full Minus Green	2	3	512	1023	
-99% to -1%	4	126	1024	32511	
Neutral / No Effect	127	128	32512	33023	
1% to 99%	129	251	33024	64511	
Full Plus Green	252	253	64512	65023	
Neutral / No Effect	254	255	65024	65535	

**Welding - P5: Crossfade from CCT to Color**

Function	8 bit value		16 bit value		Note
	From	To	From	To	
Linear Crossfade	0	255	0	65535	Default @ 0

**Welding - P6: Hue**

Function	8 bit value		16 bit value		Note
	From	To	From	To	
0 - 360°	0	255	0	65535	Default @ 0

**Welding - P7: Saturation**

Function	8 bit value		16 bit value		Note
	From	To	From	To	
0 - 100%	0	255	0	65535	Default @ 0

**Control Channel**

Function	8 bit value		16 bit value		Note
	From	To	From	To	
SAFE	0	1	-	-	Default @ 0 Hold 3s to take function
RGBW MODE	2	3	-	-	
RGB MODE	4	5	-	-	
CMY MODE	6	7	-	-	
HSI MODE	8	9	-	-	
Backlight ON	10	11	-	-	
Backlight 10S	12	13	-	-	
Backlight 20S	14	15	-	-	
Backlight 30S	16	17	-	-	
Flip Display On	18	19	-	-	
Flip Display Off	20	21	-	-	
Key Lock On	22	23	-	-	
Key Lock Off	24	25	-	-	
Calibration On	26	27	-	-	
Calibration Off	28	29	-	-	
Dimmer Curve Linear	30	31	-	-	
Dimmer Curve S-Curve	32	33	-	-	
Dimmer Curve Square Law	34	35	-	-	
Dimmer Curve Inv. Square Law	36	37	-	-	
Dimmer Curve High Res@Low	38	39	-	-	
Dimmer Speed Auto	40	41	-	-	
Dimmer Speed Fast	42	43	-	-	
Dimmer Speed Medium	44	45	-	-	
Dimmer Speed Slow	46	47	-	-	
Dimmer End Fade Off@End	48	49	-	-	
Dimmer End Snap Off@End	50	51	-	-	
Led Frequency 600 Hz	52	53	-	-	
Led Frequency 1200 Hz	54	55	-	-	
Led Frequency 2000 Hz	56	57	-	-	
Led Frequency 4000 Hz	58	59	-	-	
Led Frequency 6000 Hz	60	61	-	-	
Led Frequency 10 kHz	62	63	-	-	
Led Frequency 12 kHz	64	65	-	-	
Led Frequency 15 kHz	66	67	-	-	
Led Frequency 20 kHz	68	69	-	-	
Led Frequency 25 kHz	70	71	-	-	
Led Frequency 36 kHz	72	73	-	-	
Led Frequency 40 kHz	74	75	-	-	
Reserved	76	77	-	-	
Reserved	78	79	-	-	
Reserved	80	81	-	-	
Reserved	82	83	-	-	
Reserved	84	85	-	-	
Reserved	86	87	-	-	
Reserved	88	89	-	-	

**Control Channel**

Function	8 bit value		16 bit value		Note
	From	To	From	To	
DMX Fault Hold	90	91	-	-	
DMX Fault Blackout	92	93	-	-	
DMX Fault Standalone	94	95	-	-	
DMX Fault Emergency	96	97	-	-	
Reserved	98	99	-	-	
Reserved	100	101	-	-	
Reserved	102	103	-	-	
Reserved	104	105	-	-	
Reserved	106	107	-	-	
Reserved	108	109	-	-	
Reserved	110	111	-	-	
Reserved	112	113	-	-	
Tungsten Emulation On	114	115	-	-	
Tungsten Emulation Off	116	117	-	-	
Reserved	118	119	-	-	
Reserved	120	121	-	-	
Invert Mapping Off	122	123	-	-	
Invert Mapping On	124	125	-	-	
Standalone MASTER	126	127	-	-	
Standalone MASTER NO DMX	128	129	-	-	
Standalone SLAVE	130	131	-	-	
Standalone CINE FX	132	133	-	-	
Standalone SOURCE EMULATION	134	135	-	-	
Standalone CCT	136	137	-	-	
Standalone HSI	138	139	-	-	
Standalone FIXED COLORS	140	141	-	-	
Standalone WHITE PRESETS	142	143	-	-	
Standalone COLOR MACRO	144	145	-	-	
Standalone MANUAL COLORS	146	147	-	-	
Standalone XY	148	149	-	-	
Standalone USER PRESETS	150	151	-	-	
Standalone TOUR FX	152	153	-	-	
Fan Mode CO AUTO	154	155	-	-	
Fan Mode CO HIGH	156	157	-	-	
Fan Mode CO SILENT 1	158	159	-	-	
Fan Mode CO SILENT 2	160	161	-	-	
Fan Mode CO OFF	162	163	-	-	
Fan Mode DO AUTO	164	165	-	-	
Fan Mode DO HIGH	166	167	-	-	
Fan Mode DO SILENT 1	168	169	-	-	
Fan Mode DO SILENT 2	170	171	-	-	
Fan Mode DO OFF	172	173	-	-	
Reserved	174	253	-	-	
Reset all channel controlled	254	255	-	-	

## LEGACY MODES

Following DMX Modes are borrowed from current ECLPANELTWC series.

All channel values below are not referred or referring to any info described before.

### THEATER

CH	1 Ch	2 Ch	4 Ch	5 Ch "1"	5 Ch "2"	6 Ch	10 Ch	15 Ch	17 Ch	21 Ch
1	DIMMER	DIMMER	DIMMER	DIMMER	DIMMER	DIMMER	DIMMER	DIMMER	DIMMER	DIMMER
2		DIMMER FADE	CCT	DIMMER FINE	CCT	CCT	RED	DIMMER FINE	DIMMER FINE	DIMMER FINE
3			HUE	CCT	HUE	HUE	GREEN	RED	STROBE	STROBE
4			DIMMER FADE	HUE	STROBE	STROBE	BLUE	RED FINE	CCT	CCT
5				DIMMER FADE	DIMMER FADE	COLOR MACRO	WHITE	GREEN	HUE	HUE
6						DIMMER FADE	CCT	GREEN FINE	CROSSFADE	CROSSFADE
7							HUE	BLUE	RED	RED
8							STROBE	BLUE FINE	RED FINE	RED FINE
9							COLOR MACRO	WHITE	GREEN	GREEN
10							DIMMER FADE	WHITE FINE	GREEN FINE	GREEN FINE
11								CCT	BLUE	BLUE
12								HUE	BLUE FINE	BLUE FINE
13								STROBE	WHITE	WHITE
14								COLOR MACRO	WHITE FINE	WHITE FINE
15								DIMMER FADE	COLOR MACRO	COLOR MACRO
16									CTO ON COLORS	CTO ON COLORS
17									DIMMER FADE	DIMMER FADE
18										FX SELEC- TION
19										FX SPEED
20										FX FADE
21										CONTROL

## THEATER

1 Ch	2 Ch	4 Ch	5 Ch "1"	5 Ch "2"	6 Ch	10 Ch	15 Ch	17 Ch	21 Ch	FUNCTION	DMX Value	Default
1	1	1	1	1	1	1	1	1	1	<b>DIMMER</b> 0÷100%	000 ÷ 255	000
			2				2	2	2	<b>DIMMER FINE</b> 0÷100%	000 ÷ 255	000
								5	5	<b>HUE</b> 25 to 0 0 0 to +25	000 ÷ 126 127 ÷ 127 128 ÷ 255	127
								6	6	<b>CROSSFADE FROM CCT TO COLOR</b> 0÷100%	000 ÷ 255	000
						2	3	7	7	<b>RED</b> 0÷100%	000 ÷ 255	000
							4	8	8	<b>RED FINE</b> 0÷100%	000 ÷ 255	000
						3	5	9	9	<b>GREEN</b> 0÷100%	000 ÷ 255	000
							6	10	10	<b>GREEN FINE</b> 0÷100%	000 ÷ 255	000
						4	7	11	11	<b>BLUE</b> 0÷100%	000 ÷ 255	000
							8	12	12	<b>BLUE FINE</b> 0÷100%	000 ÷ 255	000
						5	9	13	13	<b>WHITE</b> 0÷100%	000 ÷ 255	000
							10	14	14	<b>WHITE FINE</b> 0÷100%	000 ÷ 255	000
		2	3	2	2			4	4	<b>CCT</b> 2800K - 3200K 3200K - 3500K 3500K - 4000K 4000K - 4500K 4500K - 5000K 5000K - 5600K 5600K - 6000K 6000K - 6500K	000 ÷ 031 032 ÷ 063 064 ÷ 095 096 ÷ 127 128 ÷ 159 160 ÷ 191 192 ÷ 223 224 ÷ 255	000
						6	11			<b>CCT</b> 2800K - 3200K 3200K - 3500K 3500K - 4000K 4000K - 4500K 4500K - 5000K 5000K - 5600K 5600K - 6000K 6000K - 6500K No Function	000 ÷ 030 031 ÷ 060 061 ÷ 090 091 ÷ 120 121 ÷ 150 151 ÷ 180 181 ÷ 210 211 ÷ 240 241 ÷ 255	000
		3	4	3	3	7	12			<b>HUE</b> 0 -25°÷+25°	000 ÷ 000 001 ÷ 255	000
				4	4	8	13	3	3	<b>STROBE</b> Closed Strobe slow to fast Open Random slow to fast Open	000 ÷ 030 031 ÷ 100 101 ÷ 130 131 ÷ 200 201 ÷ 255	255
					5	9	14	15		<b>COLOR MACRO</b> No Function Amber Shift on Color Macro*	000 ÷ 002 003 ÷ 005 006 ÷ 255	000

1 Ch	2 Ch	4 Ch	5 Ch "1"	5 Ch "2"	6 Ch	10 Ch	15 Ch	17 Ch	21 Ch	FUNCTION	DMX Value	Default
								16	16	<b>CTO ON COLORS</b> 0+100%	000 ÷ 255	000
	2	4	5	5	6	10	15	17	17	<b>DIMMER FADE</b> Read from menu 0+100%	000 ÷ 000 001 ÷ 255	000
									18	<b>FX SELECTION</b> No Function Effect 1 Effect 2 Effect 3 Effect 4 Effect 5 Candle Cop Car1 Cop Car2 Cop Car3 Fire Fireworks Paparazzi Television Party Clouds Club Color Chase Strobe Lighting Explosion Fluorescent Process Pulsing Welding	000 ÷ 010 011 ÷ 020 021 ÷ 030 031 ÷ 040 041 ÷ 050 051 ÷ 060 061 ÷ 070 071 ÷ 080 081 ÷ 090 091 ÷ 100 101 ÷ 110 111 ÷ 120 121 ÷ 130 131 ÷ 140 141 ÷ 150 151 ÷ 160 161 ÷ 170 171 ÷ 180 181 ÷ 190 191 ÷ 200 201 ÷ 210 211 ÷ 220 221 ÷ 230 231 ÷ 240 241 ÷ 255	000
									19	<b>FX SPEED</b> 0+100%	000 ÷ 255	000
									20	<b>FX FADE</b> 0+100%	000 ÷ 255	000
									21	<b>CONTROL CHANNEL</b> SAFE RGBW MODE RGB MODE CMY MODE HSI MODE Backlight ON Backlight 10S Backlight 20S Backlight 30S Flip Display On Flip Display Off Key Lock On Key Lock Off Calibration On Calibration Off Dimmer Curve Linear Dimmer Curve S-Curve Dimmer Curve Square Law Dimmer Curve Inv. Square Law Dimmer Curve High Res@Low Dimmer Speed Auto Dimmer Speed Fast Dimmer Speed Medium Dimmer Speed Slow Dimmer End Fade Off@End Dimmer End Snap Off@End Led Frequency 600 Hz Led Frequency 1200 Hz Led Frequency 2000 Hz Led Frequency 4000 Hz Led Frequency 6000 Hz Led Frequency 10 kHz Led Frequency 12 kHz Led Frequency 15 kHz Led Frequency 20 kHz Led Frequency 25 kHz	0 ÷ 1 2 ÷ 3 4 ÷ 5 6 ÷ 7 8 ÷ 9 10 ÷ 11 12 ÷ 13 14 ÷ 15 16 ÷ 17 18 ÷ 19 20 ÷ 21 22 ÷ 23 24 ÷ 25 26 ÷ 27 28 ÷ 29 30 ÷ 31 32 ÷ 33 34 ÷ 35 36 ÷ 37 38 ÷ 39 40 ÷ 41 42 ÷ 43 44 ÷ 45 46 ÷ 47 48 ÷ 49 50 ÷ 51 52 ÷ 53 54 ÷ 55 56 ÷ 57 58 ÷ 59 60 ÷ 61 62 ÷ 63 64 ÷ 65 66 ÷ 67 68 ÷ 69 70 ÷ 71	000

1 Ch	2 Ch	4 Ch	5 Ch "1"	5 Ch "2"	6 Ch	10 Ch	15 Ch	17 Ch	21 Ch	FUNCTION	DMX Value	Default
									21	<b>CONTROL CHANNEL</b>		
										Led Frequency 36 kHz	72 + 73	
										Led Frequency 40 kHz	74 + 75	
										Reserved	76 + 77	
										Reserved	78 + 79	
										Reserved	80 + 81	
										Reserved	82 + 83	
										Reserved	84 + 85	
										Reserved	86 + 87	
										Reserved	88 + 89	
										DMX Fault Hold	90 + 91	
										DMX Fault Blackout	92 + 93	
										DMX Fault Standalone	94 + 95	
										DMX Fault Emergency	96 + 97	
										Reserved	98 + 99	
										Reserved	100 + 101	
										Reserved	102 + 103	
										Reserved	104 + 105	
										Reserved	106 + 107	
										Reserved	108 + 109	
										Reserved	110 + 111	
										Reserved	112 + 113	
										Tungsten Emulation On	114 + 115	
										Tungsten Emulation Off	116 + 117	
										Reserved	118 + 119	
										Reserved	120 + 121	
										Invert Mapping Off	122 + 123	
										Invert Mapping On	124 + 125	
										Standalone MASTER	126 + 127	
										Standalone MASTER NO DMX	128 + 129	
										Standalone SLAVE	130 + 131	
										Standalone CINE FX	132 + 133	
										Standalone SOURCE EMULATION	134 + 135	
										Standalone CCT	136 + 137	
										Standalone HSI	138 + 139	
										Standalone FIXED COLORS	140 + 141	
										Standalone WHITE PRESETS	142 + 143	
										Standalone COLOR MACRO	144 + 145	
										Standalone MANUAL COLORS	146 + 147	
										Standalone XY	148 + 149	
										Standalone USER PRESETS	150 + 151	
										Standalone TOUR FX	152 + 153	
										Fan Mode CO AUTO	154 + 155	
										Fan Mode CO HIGH	156 + 157	
										Fan Mode CO SILENT 1	158 + 159	
										Fan Mode CO SILENT 2	160 + 161	
										Fan Mode CO OFF	162 + 163	
										Fan Mode DO AUTO	164 + 165	
										Fan Mode DO HIGH	166 + 167	
										Fan Mode DO SILENT 1	168 + 169	
										Fan Mode DO SILENT 2	170 + 171	
										Fan Mode DO OFF	172 + 173	
										Reserved	174 + 253	
										Reset all channel controlled	254 + 255	

1 Ch	2 Ch	4 Ch	5 Ch "1"	5 Ch "2"	6 Ch	10 Ch	15 Ch	17 Ch	21 Ch	FUNCTION	DMX Value	Default
										<b>COLOR MACRO</b>		
										Open	000 ÷ 001	
										Red	002 ÷ 003	
										Green	004 ÷ 005	
										Blue	006 ÷ 007	
										Cyan	008 ÷ 009	
										Magenta	010 ÷ 011	
										Yellow	012 ÷ 013	
										Dirty White	014 ÷ 015	
										Alice Blue	016 ÷ 017	
										Congo Blue	018 ÷ 019	
										Dark Steel Blue	020 ÷ 021	
										Deep Lavender	022 ÷ 023	
										Lilac Ting	024 ÷ 025	
										Daylight Blue	026 ÷ 027	
										Flame Red	028 ÷ 029	
										Bastard Amber	030 ÷ 031	
										Deep Orange	032 ÷ 033	
										Pale Gold	034 ÷ 035	
										Apricot	036 ÷ 037	
										Bright Blue	038 ÷ 039	
										Primary Green	040 ÷ 041	
										Special Lavender	042 ÷ 043	
										Pale Lavender	044 ÷ 045	
										Deep Golden Amber	046 ÷ 047	
										Medium Blue	048 ÷ 049	
										Bright Pink	050 ÷ 051	
								15		Mauve	052 ÷ 053	
										Dark Green	054 ÷ 055	000
										Lee Green	056 ÷ 057	
										Dark Blue	058 ÷ 059	
										Light Blue	060 ÷ 061	
										Steel Blue	062 ÷ 063	
										Medium Blue-Green	064 ÷ 065	
										Peacock Blue	066 ÷ 067	
										Magenta	068 ÷ 069	
										Dark Pink	070 ÷ 071	
										Middle Rose	072 ÷ 073	
										Light Salmon	074 ÷ 075	
										English Rose	076 ÷ 077	
										Light Rose	078 ÷ 079	
										Orange	080 ÷ 081	
										Deep Amber	082 ÷ 083	
										Straw	084 ÷ 085	
										Light Amber	086 ÷ 087	
										Spring Yellow	088 ÷ 089	
										Dark Yellow Green	090 ÷ 091	
										Just Blue	092 ÷ 093	
										Sky Blue	094 ÷ 095	
										Lavender	096 ÷ 097	
										Light Lavender	098 ÷ 099	
										Pink Carnation	100 ÷ 101	
										Medium Pink	102 ÷ 103	
										Light Pink	104 ÷ 105	
										Sunset Red	106 ÷ 107	
										Dark Amber	108 ÷ 109	
										Gold Amber	110 ÷ 111	



1 Ch	2 Ch	4 Ch	5 Ch "1"	5 Ch "2"	6 Ch	10 Ch	15 Ch	17 Ch	21 Ch	FUNCTION	DMX Value	Default
										Medium Amber	112 ÷ 113	000
										Fire	114 ÷ 115	
										Surprise Peach	116 ÷ 117	
										Straw Tint	118 ÷ 119	
										Medium Yellow	120 ÷ 121	
										Lee Minus Green	122 ÷ 123	
										Pale Gold	124 ÷ 125	
										Orange	126 ÷ 127	
										Deep Straw	128 ÷ 129	
										Rose Purple	130 ÷ 131	
										Deep Purple	132 ÷ 133	
										Soft Green	134 ÷ 135	
									15	Reserved	136 ÷ 211	
										2800K	212 ÷ 213	
										3000K	214 ÷ 215	
										3200K	216 ÷ 217	
										3400K	218 ÷ 219	
										3600K	220 ÷ 221	
										3800K	222 ÷ 223	
										4000K	224 ÷ 225	
										4200K	226 ÷ 227	
										4400K	228 ÷ 229	
										4600K	230 ÷ 231	
										4800K	232 ÷ 233	
										5000K	234 ÷ 235	
										5200K	236 ÷ 237	
										5400K	238 ÷ 239	
										5600K	240 ÷ 241	
										6000K	242 ÷ 243	
										6500K	244 ÷ 245	
										7000K	246 ÷ 247	
										8000K	248 ÷ 249	
										9000K	250 ÷ 251	
										10000K	252 ÷ 253	
										Full On	254 ÷ 255	

PIXEL LAYOUT

The following drawing describes the pixels distribution and their position on the product light emitting surface. Check the DMX mode selected to identify the related Pixel layout.



LUMIPIXXB050 - 1 Pixel



LUMIPIXXB100 - 1 Pixel

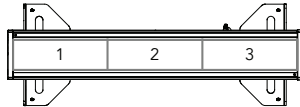

LUMIPIXXB050 - 3 Pixel



LUMIPIXXB100 - 3 Pixel

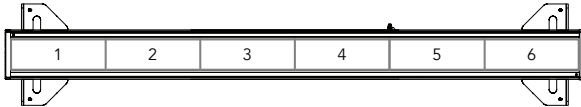

LUMIPIXXB100 - 6 Pixel

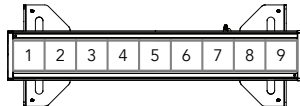

LUMIPIXXB050 - 9 Pixel

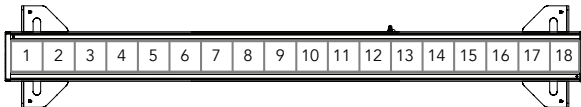

LUMIPIXXB100 - 18 Pixel

<b>LUMIPIXXB050</b>			
<b>PIXEL DMX CHART (FIXTURE ENGINE)</b>			
<b>This modes are running on the Fixture Engine level.</b>			
<b>MODE</b>			
<b>PARAMETER</b>	<b>1 PIX</b>	<b>3 PIX</b>	<b>9 PIX</b>
RED 1	1	1	1
GREEN 1	2	2	2
BLUE 1	3	3	3
WARM WHITE 1	4	4	4
...	-	...	...
RED 3	-	9	9
GREEN 3	-	10	10
BLUE 3	-	11	11
WARM WHITE 3	-	12	12
...	-	-	...
RED 9	-	-	33
GREEN 9	-	-	34
BLUE 9	-	-	35
WARM WHITE 9	-	-	36

<b>LUMIPIXXB100</b>				
<b>PIXEL DMX CHART (FIXTURE ENGINE)</b>				
<b>This modes are running on the Fixture Engine level.</b>				
<b>MODE</b>				
<b>PARAMETER</b>	<b>1 PIX</b>	<b>3 PIX</b>	<b>6 PIX</b>	<b>18PX</b>
RED 1	1	1	1	1
GREEN 1	2	2	2	2
BLUE 1	3	3	3	3
WARM WHITE 1	4	4	4	4
...	-	...	...	...
RED 3	-	9	9	9
GREEN 3	-	10	10	10
BLUE 3	-	11	11	11
WARM WHITE 3	-	12	12	12
...	-	-	...	...
RED 6	-	-	21	21
GREEN 6	-	-	22	22
BLUE 6	-	-	23	23
WARM WHITE 6	-	-	24	24
...	-	-	-	...
RED 18	-	-	-	69
GREEN 18	-	-	-	70
BLUE 18	-	-	-	71
WARM WHITE 18	-	-	-	72

## FILM

Ch	1M12CH	2M20CH
1	DIMMER	DIMMER
2	CCT	DIMMER FINE
3	HUE	CCT
4	CROSSFADE FROM CCT TO COLOR	CCT FINE
5	RED	HUE
6	GREEN	HUE FINE
7	BLUE	CROSSFADE FROM CCT TO COLOR
8	WHITE	CROSSFADE FROM CCT TO COLOR FINE
9	FAN CONTROL	RED
10	COLOR MACRO	RED FINE
11	STROBE	GREEN
12	CONTROL	GREEN FINE
13		BLUE
14		BLUE FINE
15		WHITE
16		WHITE FINE
17		FAN CONTROL
18		COLOR MACRO
19		STROBE
20		CONTROL
21		
22		
23		
24		
25		
26		
27		
28		
29		
30		
31		
32		
33		

**FILM**  
1M12CH and 2M20CH



1M12CH	2M20CH	FUNCTION	DMX Value	Default
1	1	<b>DIMMER</b> 0÷100%	000 ÷ 255	000
	2	<b>DIMMER FINE</b>	000 ÷ 255	000
2	3	<b>CCT</b> 2800K - 3000K 3000K - 3200K 3200K - 3400K 3400K - 3600K 3600K - 3800K 3800K - 4000K 4000K - 4200K 4200K - 4400K 4400K - 4600K 4600K - 4800K 4800K - 5000K 5000K - 5200K 5200K - 5400K 5400K - 5600K 5600K - 5800K 5800K - 6000K 6000K - 6200K 6200K - 6400K 6400K - 6600K 6600K - 6800K 6800K - 7000K 7000K - 7200K 7200K - 7400K 7400K - 7600K 7600K - 7800K 7800K - 8000K 8000K - 8200K 8200K - 8400K 8400K - 8600K 8600K - 8800K 8800K - 9000K 9000K - 9200K 9200K - 9400K 9400K - 9600K 9600K - 9800K 9800K - 10000K	000 ÷ 007 007 ÷ 014 014 ÷ 021 021 ÷ 028 028 ÷ 035 035 ÷ 042 042 ÷ 049 049 ÷ 056 056 ÷ 063 063 ÷ 070 070 ÷ 077 077 ÷ 084 084 ÷ 091 091 ÷ 098 098 ÷ 105 105 ÷ 112 112 ÷ 119 119 ÷ 126 126 ÷ 133 133 ÷ 140 140 ÷ 147 147 ÷ 154 154 ÷ 161 161 ÷ 168 168 ÷ 175 175 ÷ 182 182 ÷ 189 189 ÷ 196 196 ÷ 203 203 ÷ 210 210 ÷ 217 217 ÷ 224 224 ÷ 231 231 ÷ 238 238 ÷ 245 245 ÷ 255	000
	4	<b>CCT FINE</b>	000 ÷ 255	000
3	5	<b>HUE</b> Neutral / no effect Full minus green -99% --> -1% Neutral / no effect 1% --> 99% Full plus green	000 ÷ 010 011 ÷ 020 021 ÷ 119 120 ÷ 145 146 ÷ 244 245 ÷ 255	000
	6	<b>HUE FINE</b>	000 ÷ 255	000
4	7	<b>CROSSFADE FROM CCT TO COLOR</b> 0÷100%	000 ÷ 255	000
	8	<b>CROSSFADE FROM CCT TO COLOR FINE</b>	000 ÷ 255	000
5	9	<b>RED</b> 0÷100%	000 ÷ 255	000

1M12CH	2M20CH	FUNCTION	DMX Value	Default
	10	<b>RED FINE</b>	000 ÷ 255	000
6	11	<b>GREEN</b> 0÷100%	000 ÷ 255	000
	12	<b>GREEN FINE</b>	000 ÷ 255	000
7	13	<b>BLUE</b> 0÷100%	000 ÷ 255	000
	14	<b>BLUE FINE</b>	000 ÷ 255	000
8	15	<b>WHITE</b> 0÷100%	000 ÷ 255	000
	16	<b>WHITE FINE</b>	000 ÷ 255	000
9	17	<b>FAN CONTROL</b> Use Fan Mode setting of fixture menu Fan Mode DO SILENT 1 Fan Mode DO AUTO Fan Mode DO HIGH Not Used Fan Mode DO SILENT 2 Fan Mode DO OFF	000 ÷ 009 010 ÷ 057 058 ÷ 105 106 ÷ 153 154 ÷ 201 202 ÷ 249 250 ÷ 255	000
10	18	<b>COLOR MACRO</b> Open Red Green Blue Cyan Magenta Yellow Dirty White Alice Blue Congo Blue Dark Steel Blue Deep Lavender Lilac Ting Daylight Blue Flame Red Bastard Amber Deep Orange Pale Gold Apricot Bright Blue Primary Green Special Lavender Pale Lavender Deep Golden Amber Medium Blue Bright Pink Mauve Dark Green Lee Green Dark Blue Light Blue Steel Blue Medium Blue-Green Peacock Blue Magenta Dark Pink Middle Rose Light Salmon English Rose Light Rose Orange Deep Amber Straw Light Amber Spring Yellow Dark Yellow Green Just Blue Sky Blue Lavender Light Lavender	000 ÷ 001 002 ÷ 003 004 ÷ 005 006 ÷ 007 008 ÷ 009 010 ÷ 011 012 ÷ 013 014 ÷ 015 016 ÷ 017 018 ÷ 019 020 ÷ 021 022 ÷ 023 024 ÷ 025 026 ÷ 027 028 ÷ 029 030 ÷ 031 032 ÷ 033 034 ÷ 035 036 ÷ 037 038 ÷ 039 040 ÷ 041 042 ÷ 043 044 ÷ 045 046 ÷ 047 048 ÷ 049 050 ÷ 051 052 ÷ 053 054 ÷ 055 056 ÷ 057 058 ÷ 059 060 ÷ 061 062 ÷ 063 064 ÷ 065 066 ÷ 067 068 ÷ 069 070 ÷ 071 072 ÷ 073 074 ÷ 075 076 ÷ 077 078 ÷ 079 080 ÷ 081 082 ÷ 083 084 ÷ 085 086 ÷ 087 088 ÷ 089 090 ÷ 091 092 ÷ 093 094 ÷ 095 096 ÷ 097 098 ÷ 099	000

1M12CH	2M20CH	FUNCTION	DMX Value	Default
10	18	Pink Carnation	100 + 101	000
		Medium Pink	102 + 103	
		Light Pink	104 + 105	
		Sunset Red	106 + 107	
		Dark Amber	108 + 109	
		Gold Amber	110 + 111	
		Medium Amber	112 + 113	
		Fire	114 + 115	
		Surprise Peach	116 + 117	
		Straw Tint	118 + 119	
		Medium Yellow	120 + 121	
		Lee Minus Green	122 + 123	
		Pale Gold	124 + 125	
		Orange	126 + 127	
		Deep Straw	128 + 129	
		Rose Purple	130 + 131	
		Deep Purple	132 + 133	
		Soft Green	134 + 135	
		Reserved	136 + 211	
		2800K	212 + 213	
		3000K	214 + 215	
		3200K	216 + 217	
		3400K	218 + 219	
		3600K	220 + 221	
		3800K	222 + 223	
		4000K	224 + 225	
		4200K	226 + 227	
		4400K	228 + 229	
		4600K	230 + 231	
		4800K	232 + 233	
		5000K	234 + 235	
		5200K	236 + 237	
		5400K	238 + 239	
5600K	240 + 241			
6000K	242 + 243			
6500K	244 + 245			
7000K	246 + 247			
8000K	248 + 249			
9000K	250 + 251			
10000K	252 + 253			
Full On	254 + 255			
11	19	<b>STROBE</b>		000
		Open	000-019	
		1 flash/s -> 25 flashes/s	020-255	
12	20	<b>CONTROL CHANNEL</b>		000
		SAFE	0 + 1	
		RGBW MODE	2 + 3	
		RGB MODE	4 + 5	
		CMY MODE	6 + 7	
		HSI MODE	8 + 9	
		Backlight ON	10 + 11	
		Backlight 10S	12 + 13	
		Backlight 20S	14 + 15	
		Backlight 30S	16 + 17	
		Flip Display On	18 + 19	
		Flip Display Off	20 + 21	
		Key Lock On	22 + 23	
		Key Lock Off	24 + 25	
		Calibration On	26 + 27	
		Calibration Off	28 + 29	
		Dimmer Curve Linear	30 + 31	
		Dimmer Curve S-Curve	32 + 33	
		Dimmer Curve Square Law	34 + 35	
		Dimmer Curve Inv. Square Law	36 + 37	
		Dimmer Curve High Res@Low	38 + 39	
		Dimmer Speed Auto	40 + 41	
		Dimmer Speed Fast	42 + 43	
		Dimmer Speed Medium	44 + 45	
		Dimmer Speed Slow	46 + 47	
		Dimmer End Fade Off@End	48 + 49	
		Dimmer End Snap Off@End	50 + 51	
		Led Frequency 600 Hz	52 + 53	
		Led Frequency 1200 Hz	54 + 55	
		Led Frequency 2000 Hz	56 + 57	
		Led Frequency 4000 Hz	58 + 59	
		Led Frequency 6000 Hz	60 + 61	
		Led Frequency 10 kHz	62 + 63	
Led Frequency 12 kHz	64 + 65			
Led Frequency 15 kHz	66 + 67			
Led Frequency 20 kHz	68 + 69			
Led Frequency 25 kHz	70 + 71			

1M12CH	2M20CH	FUNCTION	DMX Value	Default
		<b>CONTROL CHANNEL</b>		
		Led Frequency 36 kHz	72 + 73	
		Led Frequency 40 kHz	74 + 75	
		Reserved	76 + 77	
		Reserved	78 + 79	
		Reserved	80 + 81	
		Reserved	82 + 83	
		Reserved	84 + 85	
		Reserved	86 + 87	
		Reserved	88 + 89	
		DMX Fault Hold	90 + 91	
		DMX Fault Blackout	92 + 93	
		DMX Fault Standalone	94 + 95	
		DMX Fault Emergency	96 + 97	
		Reserved	98 + 99	
		Reserved	100 + 101	
		Reserved	102 + 103	
		Reserved	104 + 105	
		Reserved	106 + 107	
		Reserved	108 + 109	
		Reserved	110 + 111	
		Reserved	112 + 113	
		Tungsten Emulation On	114 + 115	
		Tungsten Emulation Off	116 + 117	
		Reserved	118 + 119	
		Reserved	120 + 121	
12	20	Invert Mapping Off	122 + 123	000
		Invert Mapping On	124 + 125	
		Standalone MASTER	126 + 127	
		Standalone MASTER NO DMX	128 + 129	
		Standalone SLAVE	130 + 131	
		Standalone CINE FX	132 + 133	
		Standalone SOURCE EMULATION	134 + 135	
		Standalone CCT	136 + 137	
		Standalone HSI	138 + 139	
		Standalone FIXED COLORS	140 + 141	
		Standalone WHITE PRESETS	142 + 143	
		Standalone COLOR MACRO	144 + 145	
		Standalone MANUAL COLORS	146 + 147	
		Standalone XY	148 + 149	
		Standalone USER PRESETS	150 + 151	
		Standalone TOUR FX	152 + 153	
		Fan Mode CO AUTO	154 + 155	
		Fan Mode CO HIGH	156 + 157	
		Fan Mode CO SILENT 1	158 + 159	
		Fan Mode CO SILENT 2	160 + 161	
		Fan Mode CO OFF	162 + 163	
		Fan Mode DO AUTO	164 + 165	
		Fan Mode DO HIGH	166 + 167	
		Fan Mode DO SILENT 1	168 + 169	
		Fan Mode DO SILENT 2	170 + 171	
		Fan Mode DO OFF	172 + 173	
		Reserved	174 + 253	
		Reset all channel controlled	254 + 255	



# 13 - ACCESSORIES INSTALLATION

## BARNDOOR (CODE LPXB050BD / LPXB100BD - OPTIONAL)

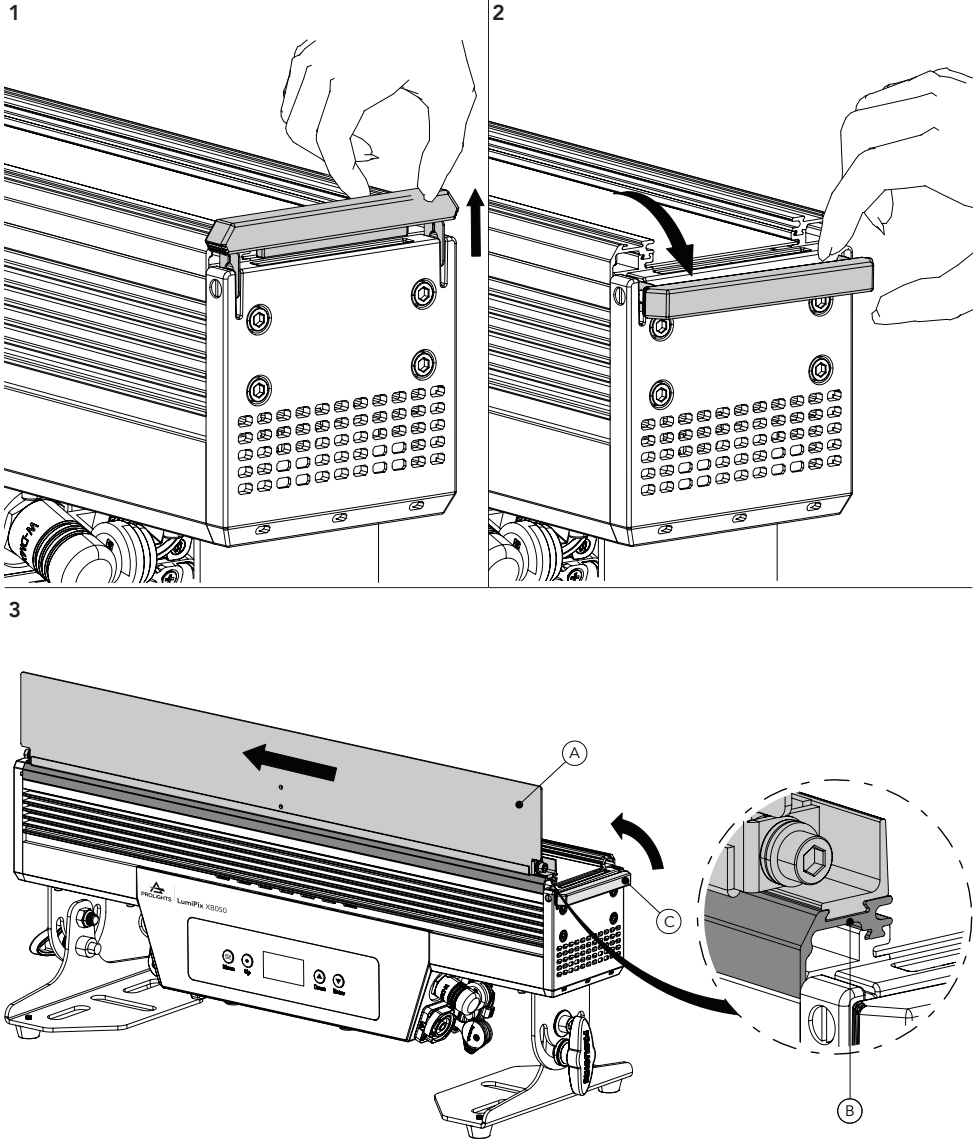

Pull the moving buckle upwards (1), then outwards (2). Insert the barndoor accessory (3-A) using the guide on the housing of the unit (B). Then reverse the step 1-2 to close the moving buckle (3-C).

Fig. 08

60° EGGCRATE (CODE LPXB050EC60 / LPXB050EC100 - OPTIONAL)

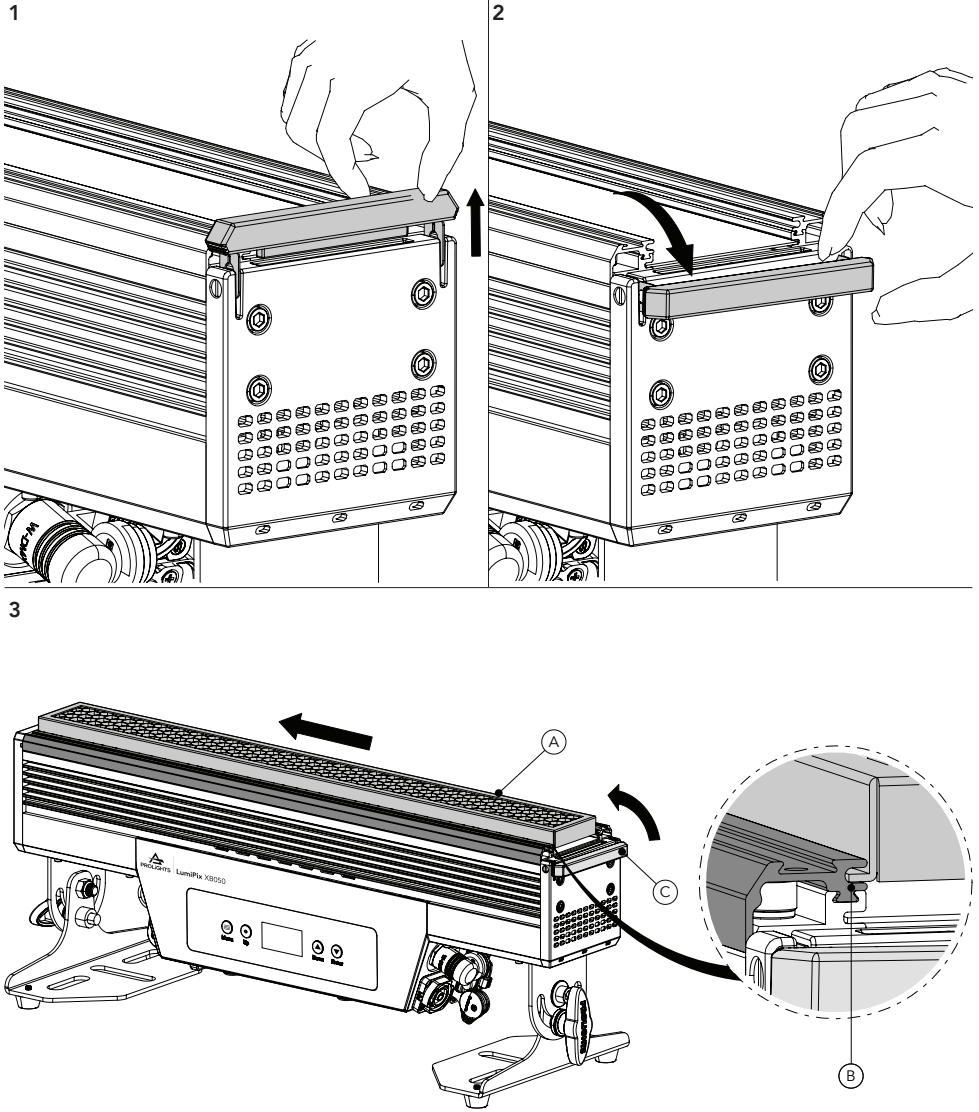

Pull the moving buckle upwards (1), then outwards (2).  
Insert the egg crate accessory (3-A) using the guide on the housing of the unit (B). Then reverse the step 1-2 to close the moving buckle (3-C).

Fig. 09

LIGHT DIFFUSION FILTER (CODE LPXB050FILT20/40/60 / LPXB100FILT20/40/60 - OPTIONAL)

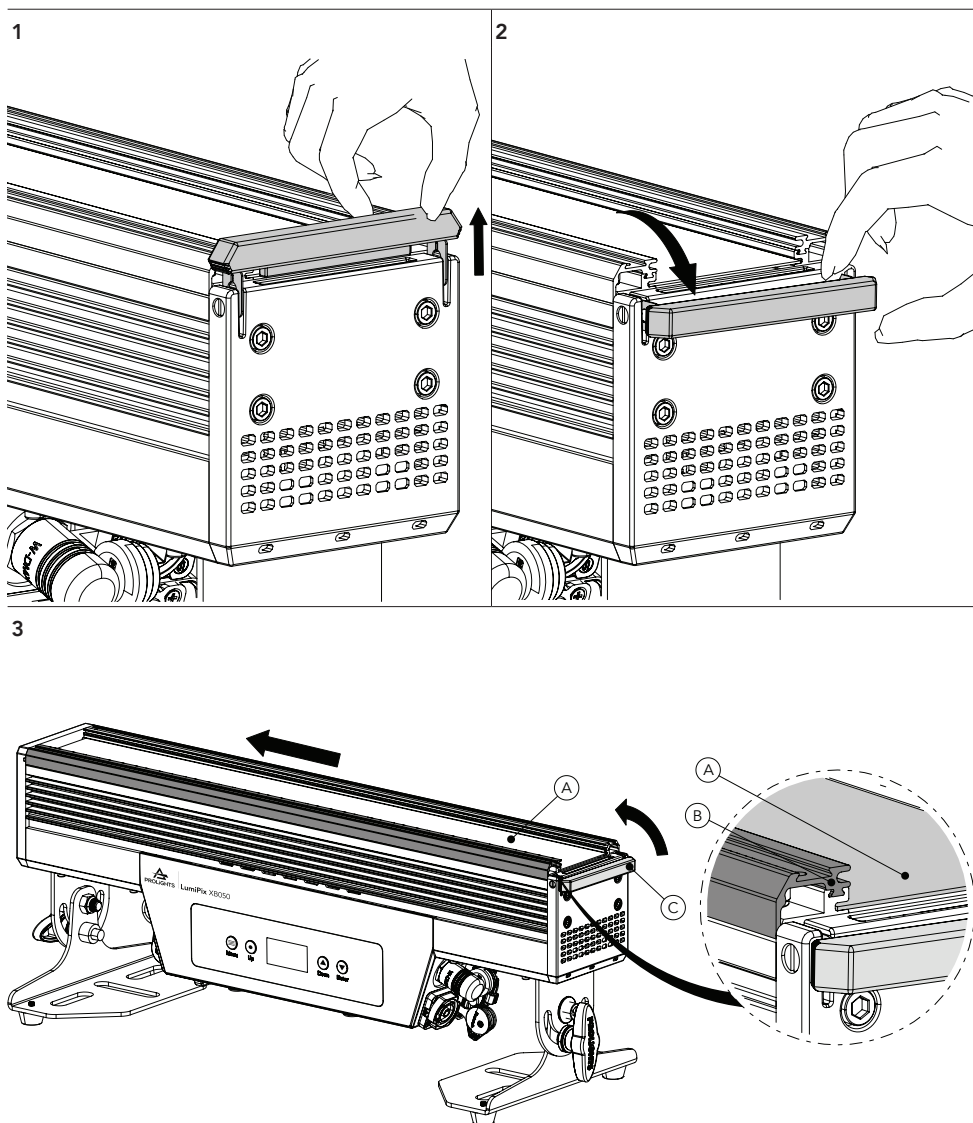

Pull the moving buckle upwards (1), then outwards (2). Insert the light diffusion filter accessory (3-A) using the guide on the housing of the unit (B). Then reverse the step 1-2 to close the moving buckle (3-C).

Fig. 09

## 14 - TEST OF IP65 RATING

To check sealing after servicing use the IPTESTBOX.

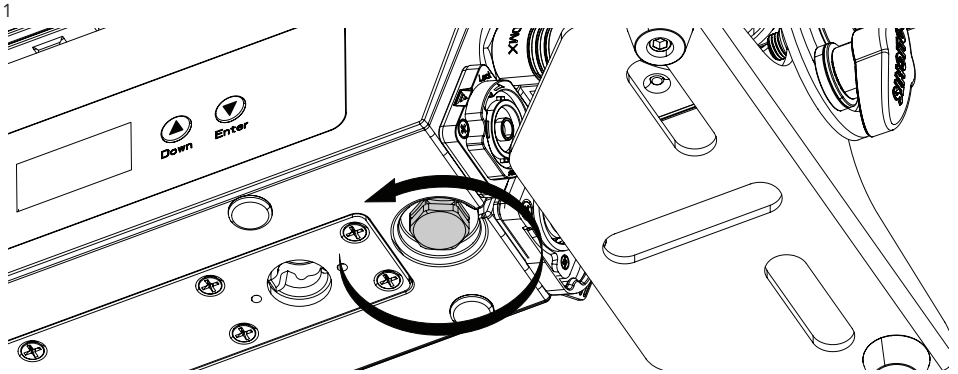

Remove the gore valve from the connections panel.

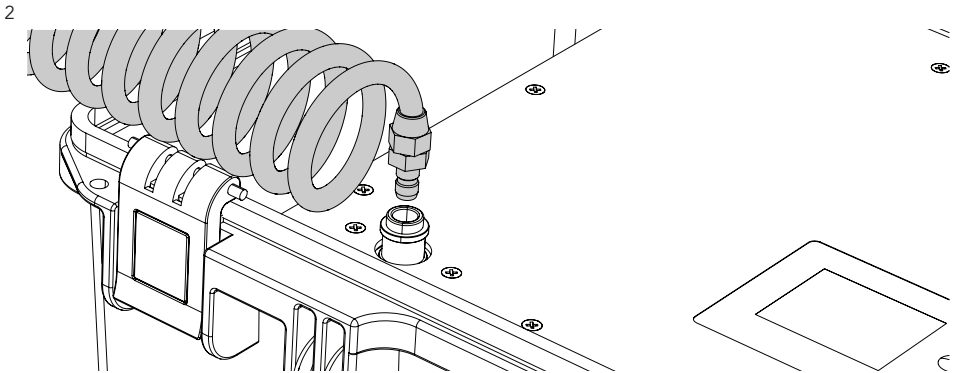

Connect the air hose to the IPTESTBOX by inserting the quick-connect fitting into the coupler.

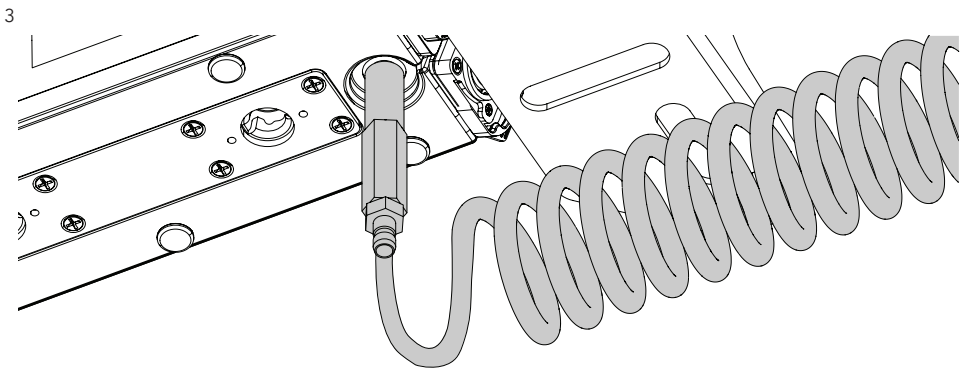

Insert the threaded end into the threaded valve hole socket.

For the operating procedure using the instrument, refer to the IPTESTBOX user manual.

Fig. 14

# 15 - MAINTENANCE

## MAINTENANCE AND CLEANING THE PRODUCT

**WARNING:** Disconnect from the mains before starting any maintenance work

It is recommended to clean the front at regular intervals, from impurities caused by dust, smoke, or other particles to ensure that the light is radiated at maximum brightness.

- For cleaning, disconnect the main plug from the socket. Use a soft, clean cloth moistened with a mild detergent. Then carefully wipe the part dry. For cleaning other housing parts use only a soft, clean cloth. Never use a liquid, it might penetrate the unit and cause damage to it.
- The user must clean the product periodically to maintain optimum performance and cooling. The user may also upload firmware (product software) to the fixture via the DMX signal input port or USB port using firmware and instructions from PROLIGHTS.
- The frequency of such maintenance operations is to be performed according to various factors, such as the amount of the use and the condition of the installation environment (air humidity, presence of dust, salinity, etc.). It is recommended that the product is subject to annual service by a qualified technician for special maintenance involving at least the following procedures:
  - General cleaning of internal parts.
  - For all the parts subject to friction, using lubricants specifically supplied by PROLIGHTS.
  - General visual check of the internal components, cabling, mechanical parts, etc.
  - Electrical, photometric and functional checks; eventual repairs.
  - Cleaning the lenses. Only use neutral soap and water to clean the lenses, then dry it carefully with a soft, non-abrasive cloth.

**WARNING:** the use of alcohol or any other detergent could damage the lenses.

- All other service operations on the product must be carried out by PROLIGHTS, its approved service agents or trained and qualified personnel.
- It is PROLIGHTS policy to apply the strictest possible calibration procedures and use the best quality materials available to ensure optimum performance and the longest possible component lifetimes. However, optical components are subject to wear and tear over the life of the product, resulting in gradual changes in colours over many thousands of hours of use. The extent of wear and tear depends heavily on operating conditions and environment, so it is impossible to specify precisely whether and to what extent performance will be affected. However, you may eventually need to replace optical components if their characteristics are affected by wear and tear after an extended period of use and if you require fixtures to perform within very precise optical and colour parameters.
- Do not apply filters, lenses or other materials on lenses or other optical components. Use only accessories approved by PROLIGHTS.

## VISUAL CHECK OF PRODUCT HOUSING

- The parts of the product cover/housing should be checked for eventual damages and breaking start at least every two months. In addition, especially the parts of the front lens holder have to be checked mechanically (by means of movement by the part) if it is firmly fastened to the fixture. If hint of a crack is found on some plastic part, do not use the product until the damaged part will be replaced.
- Cracks or another damages of the cover/housing parts can be caused by the product transportation or manipulation and also ageing process may influence materials.
- This checking is necessary for both fixed installations and preparing product for renting. Any free moving parts inside of the product, cracked cover/housing or any part of front lens not sitting properly in place need to be immediately replaced.

## TROUBLESHOOTING

Problems	Possible causes	Checks and remedies
Product doesn't power ON.	<ul style="list-style-type: none"> <li>No power to the product.</li> </ul>	<ul style="list-style-type: none"> <li>Check that power is switched ON and cables are plugged in.</li> </ul>
	<ul style="list-style-type: none"> <li>Fuse blown or internal fault.</li> </ul>	<ul style="list-style-type: none"> <li>Check if the Fuse is intact and eventually replace it if necessary.</li> <li>Contact the PROLIGHTS Service or authorized service partner. Do not remove parts and/or covers, or carry out any repairs or service that are not described in this Safety and User Manual unless you have both authorization from PROLIGHTS and the service documentation.</li> </ul>
Product reset correctly but does not respond correctly to the controller.	<ul style="list-style-type: none"> <li>Bad signal connection.</li> </ul>	<ul style="list-style-type: none"> <li>Inspect connections and cables. Fix eventual bad connections. Repair or replace damaged cables.</li> </ul>
	<ul style="list-style-type: none"> <li>Signal connection not terminated.</li> </ul>	<ul style="list-style-type: none"> <li>Insert DMX termination plug in signal output socket of the last product on the signal line.</li> </ul>
	<ul style="list-style-type: none"> <li>Incorrect addressing of the product.</li> </ul>	<ul style="list-style-type: none"> <li>Check the product address and control settings.</li> </ul>
	<ul style="list-style-type: none"> <li>One of the product is defective and is corrupting the signal transmission on the signal line.</li> </ul>	<ul style="list-style-type: none"> <li>Unplug the XLR in and out connectors and connect them directly together to bypass one product at a time until normal operation is regained. Once found the error, have that fixture serviced by a qualified technician.</li> </ul>
Timeout error after fixture reset.	<ul style="list-style-type: none"> <li>One or more hardware components requires mechanical adjustments.</li> </ul>	<ul style="list-style-type: none"> <li>Check product stored error messages for more information. Contact PROLIGHTS Service or an authorized service partner.</li> </ul>
Mechanical effect loses position.	<ul style="list-style-type: none"> <li>Mechanical hardware require cleaning, adjustment or lubrication.</li> </ul>	<ul style="list-style-type: none"> <li>Check product stored error messages for more information. Contact PROLIGHTS Service or an authorized service partner.</li> </ul>
Light output turn OFF Intermittently.	<ul style="list-style-type: none"> <li>Fixture is too hot.</li> </ul>	<ul style="list-style-type: none"> <li>Check product stored error messages.</li> <li>Allow product to cool.</li> <li>Clean the product and airflow filters.</li> <li>Reduce ambient temperature.</li> </ul>
	<ul style="list-style-type: none"> <li>Hardware failure (temperature sensor, fans, Light source...).</li> </ul>	<ul style="list-style-type: none"> <li>Check product stored error messages for more information. Contact PROLIGHTS Service or an authorized service partner.</li> </ul>
General low light intensity.	<ul style="list-style-type: none"> <li>Dirty lens assembly.</li> </ul>	<ul style="list-style-type: none"> <li>Clean the fixture regularly.</li> </ul>
	<ul style="list-style-type: none"> <li>Dirty or damaged filters.</li> </ul>	<ul style="list-style-type: none"> <li>Install lens assembly properly.</li> </ul>

Contact an authorized service center in case of technical problems or not reported in the table can not be resolved by the procedure given in the table.





**PROLIGHTS** is a trademark of  
**MUSIC & LIGHTS S.r.l.**  
**musiclights.it**

Via A.Olivetti snc  
04026 - Minturno (LT) ITALY  
Tel: +39 0771 72190

**prolights.it**  
support@prolights.it